

301

Black and White Transmission Densitometer

Operator Manual

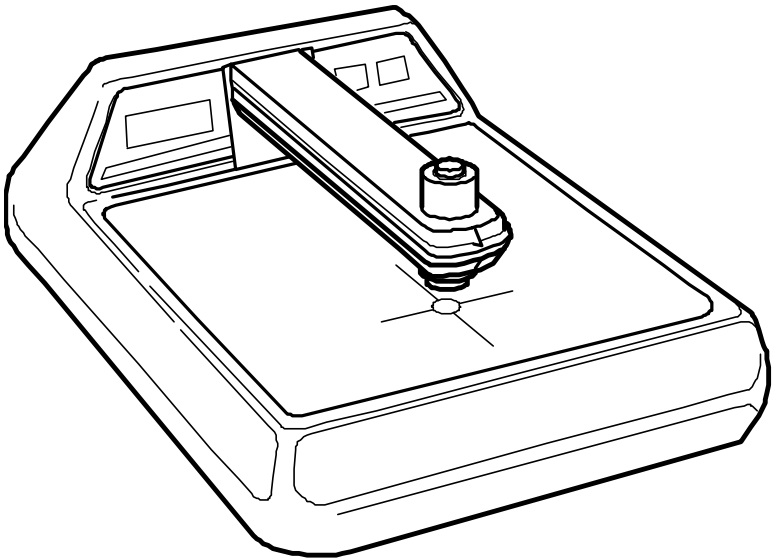

 x-rite

FCC

This equipment has been tested and found to comply with the limits for a Class A digital device, pursuant to Part 15 of the FCC Rules. These limits are designed to provide reasonable protection against harmful interference when the equipment is operated in a commercial environment. This equipment generates, uses, and can radiate radio frequency energy and, if not installed and used in accordance with the instruction manual, may cause harmful interference to radio communications. Operation of this equipment in a residential area is likely to cause harmful interference in which case the user will be required to correct the interference at his own expense.

Canada

This Class A digital apparatus meets all requirements of the Canadian Interference-Causing Equipment Regulations.

Cet appareil numérique de la classe A respecte toutes les exigences du Règlement sur le matériel brouilleur du Canada.

NOTE: Shielded interface cables must be used in order to maintain compliance with the desired FCC and European emission requirements.

For 230V~ replace with 400 mA, 5 by 20 mm fuse only

For 115V~ replace with 500 mA, 5 by 20 mm fuse only.

Para 230V~ Reemplazar solamente con el fusible 400 mA, dimensión 5mm por 20 mm.

Para 115V~ Reemplazar solamente con el fusible 500 mA, dimensión 5mm por 20 mm.

Per 230V~ Sostituire il fusibile solamente con il tipe di 400 mA, dimensione 5mm per 20 mm.

Per 115V~ Sostituire il fusibile solamente con il tipe di 500 mA, dimensione 5mm per 20 mm.

Für 230V~ bitte nur mit einer 400 mA Sicherung, Größe 5 mal 20 mm, ersetzen!

For 115V~ bitte nur mit einer 500 mA Sicherung, Größe 5 mal 20 mm, ersetzen!

Pour 230V~ remplacer seulement par un fusible de 400 mA, 5 sur 20 mm!

Pour 115V~ remplacer seulement par un fusible de 500 mA, 5 sur 20 mm!

Replace with only Same Type Lamp Assembly, X-Rite P/N 301-21.

Ersetzen Sie die Lampenmontage nur mit einer vom gleichen Typ (X-Rite P/N 301-21).

Reemplace la unidad de lampara solamente con una del mismo tipo como la pieza X-Rite 301-21.

Ne remplacer l'assemblage de lampe qu'avec un assemblage du même type (X-Rite P/N 301-21).

Sostituire il gruppo di lampada solamente con uno dello stesso tipo che come il pezzo X-Rite 301-21.

Replace with only Same Type Fluorescent Lamp Assembly, Type F6T5/D.

Ersetzen Sie die Fluoreszenzlampen-Montage nur mit einer vom gleichen Typ (Typ F6T5/D).

Reemplace la unidad de lampara fluorescente solamente con una del mismo tipo como la pieza X-Rite F6T5/D.

Ne remplacer l'assemblage de lampe fluorescente qu'avec un assemblage du même type (type F6T5/D).

Sostituire il gruppo di lampada fluorescente solamente con uno dello stesso tipo che come il pezzo X-Rite F6T5/D.

CE DECLARATION

Manufacturer's Name: X-Rite, Incorporated

Manufacturer's Address: X-Rite, Incorporated
Siemensstraße 12b • 63263 Neu-Isenburg
Germany
Phone: +49 (0) 61 02-79 57-0
Fax: +49 (0) 61 02 -79 57-57

Model Name: Densitometer

Model No.: 301

Directive(s) Conformance: EMC 89/336/EEC LVD 73/23/EEC

ROHS/WEEE

X-Rite products meet the **R**estriction of **H**azardous **S**ubstances (RoHS) Directive 2002/95/EC and European Union – **W**aste **E**lectrical and **E**lectronic **E**quipment (WEEE) Directive 2002/96/EC. Please refer to www.xrite.com for more information on X-Rite's compliance with the RoHS/WEEE directives.

Notice

This product may or may not be supplied with a detachable power cord. Use an IEC320/C7 or IEC320/C13 detachable power cord from an approved agency in your region to meet your power requirements.

Hinweis

Dieses Produkt ist mit und ohne abnehmbares Stromkabel erhältlich. Verwenden Sie das abnehmbare Kabel IEC320/C7 oder IEC320/C13 (je nach Stromversorgung), welches Sie bei einem autorisierten Händler erhalten können.

Nota

Este producto se suministra con o sin cable extraíble. Use un cable extraíble de potencia IEC320/C7 o IEC320/C13 de un proveedor autorizado en su región para adecuarse a los requisitos de potencia.

Nota

Questo prodotto viene consegnato con o senza cavo di potenza staccabile. Usare un cavo approvato IEC320/C7 o IEC320/C13 da un'agenzia autorizzata nella vostra regione per essere conforme ai requisiti di potenza.

Observação

Este produto é fornecido com ou sem cabo descartável de potência. Use um cabo aprovado IEC320/C7 ou IEC320/C13 de uma agência autorizada em sua região para atender aos requerimentos para potência.

Avis

Un câble d'alimentation électrique amovible peut être inclus avec ce produit. Utilisez un câble d'alimentation électrique amovible IEC320/C7 ou IEC320/C13 approuvé par une institution reconnue dans votre région pour satisfaire à vos exigences en matière d'alimentation électrique.

通告

本产品可能未提供可拆式电源线。请使用您所在地区的已认证机构所提供的 IEC320/C7 或 IEC320/C13 可拆式电源线，以满足您的电源要求。

使用上の注意

本製品には、取り外し可能な電源コードが付属している場合と付属していない場合があります。ご使用地域の電源をご確認の上、取り外し可能な認定コード IEC320/C7 または IEC320/C13 をお求めください。

Relamping Instructions

NOTE: Disconnect Power Before Relamping

Fluorescent Bulb(s) Replacement

Replace the Fluorescent Bulb(s) as Follows:

1. Remove the four (4) screws on the corners of the light table and remove the light table.
2. Remove the faulty bulb(s) and replace with type F6T5/D fluorescent bulb(s).
3. Locate the light table and refasten with the four (4) screws.

Anleitung zum Ersetzen der Lampe

N.B. Stromkabel muß dabei ausgezogen werden.

Zum Ersetzen der Fluoreszenz-Leuchtbirne:

Folgen Sie den folgenden Anweisungen:

1. Entfernen Sie die vier (4) Schrauben an den Ecken vom Leuchttisch und entfernen Sie die Leuchtplatte.
2. Entfernen Sie die kaputten Birnen und ersetzen Sie sie mit Fluoreszenz-Leuchtbirnen vom Typ F6T5/D.
3. Legen Sie die Leuchtplatte wieder auf den Leuchttisch und befestigen Sie sie mit den vier (4) Schrauben.

Instrucciones de reemplazar la lampara

AVISO: Interrumpa la fuente de energía antes de continuar

El reemplazo de las bombillas fluorescentes

Siga las instrucciones a continuación para reemplazar las bombillas fluorescentes:

1. Quite los cuatro (4) tornillos de los ángulos de la mesa luminosa, luego quite la mesa luminosa.
2. Reemplace las bombillas defectuosas con bombillas fluorescentes del tipo F6T5/D.
3. Coloque la mesa luminosa en su sitio y asegúrela apretando con los cuatro (4) tornillos.

Instructions pour remplacer l'ampoule d'éclairage fluorescent

ATTENTION: Pour commencer, déconnecter le cordon secteur.

Pour remplacer l'ampoule d'éclairage fluorescent

Suivre les instructions suivantes:

1. Enlever les quatre (4) vis dans les coins de la table lumineux, et démonter la plaque translucide.
2. Enlever l'ampoule d'éclairage cassé et le remplacer avec un ampoule d'éclairage fluorescent du type F6T5/D.

3. Remplacer la plaque translucide et la retenir avec les quatre (4) vis.

Istruzioni per sostituire la lampada

AVVISO: Interrompere l'energia prima di continuare

La sostituzione delle lampade fluorescenti

Eseguire l'istruzioni seguenti per sostituire le lampade fluorescenti:

1. Togliere le quattro (4) viti dei angoli del tavolo luminoso, quindi togliere il tavolo luminoso.
2. Sostituire le lampade difettose con lampade fluorescenti del tipo F6T5/D.
3. Collocare il tavolo luminoso en suo posto y assicurarlo con le quattro (4) viti.

CUSTOMER INFORMATION

These provisions are intended to state all of the rights and responsibilities between X-Rite, Incorporated and customer. They take the place of and supersede all warranties, express or implied, and whether of merchantability, fitness, or otherwise. The remedies contained in this installation and operation manual are exclusive. Customer and X-Rite, Incorporated waive all other remedies, including but limited to, consequential damages.

Limited Warranty

X-Rite, Incorporated ("X-Rite") warrants each instrument manufactured to be free of defects in material and workmanship (excluding battery pack) for a period of 12 months. This warranty shall be fulfilled by the repair or replacement, at the option of X-Rite, of any part or parts, free of charge including labor, F.O.B. its factory or authorized service center.

This warranty shall be voided by any repair, alteration, or modification, by persons other than employees of X-Rite, or those expressly authorized by X-Rite to perform repairs, and by any abuse, misuse, or neglect of the product, or by use not in accordance with X-Rite's published instructions.

X-Rite reserves the right to make changes in design and /or improvements to its products without any obligation to include these changes in any products previously manufactured. Correction of defects by repair or replacement shall constitute fulfillment of all warranty obligations on the part of X-Rite.

THIS WARRANTY IS EXPLICITLY IN LIEU OF ANY OTHER EXPRESSED OR IMPLIED WARRANTIES, INCLUDING ANY IMPLIED WARRANTY OF MERCHANTABILITY OR FITNESS FOR ANY PARTICULAR PURPOSE. THIS WARRANTY OBLIGATION IS LIMITED TO REPAIR OR REPLACEMENT OF THE UNIT RETURNED TO X-RITE OR AN AUTHORIZED SERVICE CENTER FOR THAT PURPOSE.

This agreement shall be interpreted in accordance with the laws of the State of Michigan and jurisdiction and venue shall lie with the courts of Michigan as selected by X-Rite, Incorporated. This agreement shall be interpreted in accordance with the laws of the State of Michigan and jurisdiction and venue shall lie within the courts of Michigan as selected by X-Rite, Incorporated.

Proprietary Notice

The information contained in this manual is derived from patent and proprietary data from X-Rite, Incorporated. This manual has been prepared solely for the purpose of assisting operation and maintenance personnel in their use of the X-Rite 301 Instrument.

The contents of this manual are the property of X-Rite, Incorporated and are copyrighted. Any reproduction in whole or part is strictly prohibited. Publication of this information does not imply any rights to reproduce it or use it for any purpose other than installing, operating, or maintaining the equipment described herein.

This instrument is covered by the following U.S. and foreign patents:
U.S. Patent #4,080,075 and other patents pending.

Copyright ©2007 by X-Rite, Incorporated.

“ALL RIGHTS RESERVED.”

TABLE OF CONTENTS

Customer Information..... iv
Relamping Instructions iii
Table of Contents..... vi
List of Figures vi
Introduction.....1
 Specifications.....1
 Unpacking.....3
Operating Instructions3
 Power Application3
 Aperture Replacement3
 Nulling (Zeroing) Procedure4
 Absolute Density Measurement.....4
 Density Comparison Measurement.....4
Calibration.....5
 Calibration Frequency5
 Calibration Procedure5
Maintenance7
 Cleaning.....7
 Fluorescent Bulb Replacement8
 Reading Lamp Replacement.....9
 Fuse Replacement.....10
 Factory Repair11
Troubleshooting12
Output Connection (model 301RS)13
 RS-232 Connection.....13
 Data Instruction Format.....14

LIST OF FIGURES

Figure 1. Applying Power.....2
Figure 2. Aperture Removal3
Figure 3. Calibration6
Figure 4. Calibration Step Tablet.....6
Figure 5. Cleaning Instrument Optics.....7
Figure 6. Fluorescent Lamp Access.....8
Figure 7. Lamp PC Board Access.....9
Figure 8. Densitometer PC Board Access.....10
Figure 9. Transmit Function Switch Access13

INTRODUCTION

The X-Rite 301 Black and White Densitometer is a highly accurate and reliable instrument designed for ease of operation. This unit features push button nulling and will compute density comparisons and subtractions. Voltage and temperature compensation provides drift-free operation.

SPECIFICATIONS

Size:	10.25W x 15L x 5.25H
Weight:	8.5lbs.
Range:	0 to 5.0D w/2mm and 3mm apertures 0 to 4.0D with 1mm aperture
Accuracy:	$\pm 0.02D$ $\pm 1.5\%D$ (1mm aperture, 3.5D to 4.0D)
Repeatability:	$\pm 0.01D$
Operating Temp. Range:	+10° to +40°C (+50° to 104°F)
Operating Relative Humidity:	$\leq 76\%$
Voltage Range:	301 (Domestic) 100Vac to 130Vac, 60Hz - 301X (Export) 200Vac to 240Vac, 50Hz
Power Requirement:	80VA maximum
Warm-up Time:	60 seconds
Scale Factor Stability:	$\pm 1.0\%$ per six months
Null Drift:	$\pm 0.03D$ max., $\pm 0.01D$ typical
Safety	UL 3101-01 C22.2, No. 1010-1-92
Altitude	2000m
IEC 664	Pollution Degree 2
Installation Type	Category 2
Usage	Indoor only
FCC	Part 15, Class A, Digital Device
Industry Canada	ICES-003 Issue 2, Revision 1
International	EN50081-1:1992 Class B Generic Emission Standard EN50082-1:1992 Generic Immunity Standard

NOTE: Due to heat generated by the fluorescent lamps, accuracy to the 301 Densitometer is improved with the lamps off.

Operating Instructions

UNPACKING

Remove the instrument from shipping carton. Inspect for possible damage. If any damage is noted, contact the transportation company immediately. Do nothing more until the carrier's agent has inspected the damage.

If damage is not evident, make sure the following items are included.

- *X-Rite 301 Operation Manual* (with Warranty Card)
- 1mm, 2mm and 3mm apertures (inside back cover of manual)
- Standard Reference Step Tablet (inside front cover of manual)
- 301(X) Instrument

OPERATING INSTRUCTIONS

Operation of the X-Rite 301 is very simple. Procedures of the various modes of operation are provided in the following paragraphs. When operating the instrument, use these recommended common sense suggestions to protect yourself and your instrument:

- Avoid dangerous environments (e.g., don't use instrument in damp, wet areas)
- Use proper electrical connections.
- Ensure electric cord does not interfere with work.
- Disconnect power before servicing.

POWER APPLICATION

The 301(X) is designed to operate from a standard grounded line source. Always plug the instrument into a 3-wire receptacle.

1. Plug line cord into a 3-wire grounded outlet.
2. Turn on power switch.

APERTURE REPLACEMENT

Remove the installed aperture by lifting the edge upward. Install a new or different aperture by inserting the aperture into the light source cavity, making sure that the aperture is fully seated and pressed flush against the cavity.

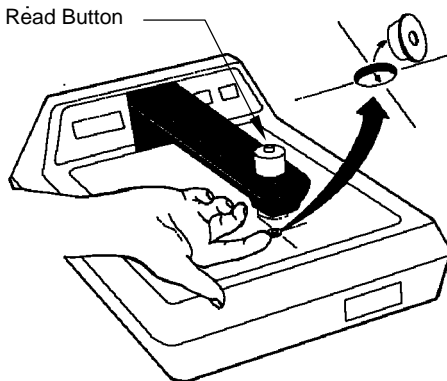

Figure 2. Aperture Removal

Operating Instructions

NULLING (ZEROING) PROCEDURE

Due to the electronic memory loss caused by power removal, null must be established each time power to the instrument is removed. Null remains very stable ($\pm 0.01D$) as long as power remains on.

Null the instrument as follows:

1. Remove film from reading area.
2. Lower the reading head by pressing the read button until it deflects totally and actuates the switch.
3. Momentarily push the null button.
4. Remove pressure on the read button to release the reading head.

NOTE: The read button is a read-hold activator. Compress the button with only as much pressure as necessary for total deflection.

ABSOLUTE DENSITY MEASUREMENT

Measure absolute density as follows:

1. Null the instrument as previously described in *Nulling (Zeroing) Procedure*.
2. Center the film area directly over the bright green light spot under the reading head.
3. Lower the reading head by pressing the read button until it totally deflects and actuates the switch.
4. Allow the instrument reading to settle to a stable number.
5. Remove pressure on the read button to release the reading head.

NOTE: Always measure density with the film emulsion side up. When measuring density values above 2.50D, ensure that reading head light seal is completely on surface of the film being measured.

DENSITY COMPARISON MEASUREMENT

Compare density readings as follows:

1. Place reference film over aperture. Press read button and momentarily press the null button.
2. Place the film to be compared over the aperture and measure density.
 - This measurement is the difference between the reference film density and the compared film density.
 - A negative (-) display indicates a lower compared film density than the reference film.

NOTE: When referencing with densities greater than 3.00D, press the null button longer to allow the instrument electronics to fully stabilize.

CALIBRATION

Calibration of this instrument should remain stable over a long period of time and over an extended range of voltage and temperature. However, a calibrated step tablet is provided (inside front cover) to verify the instrument calibration. Handle the step tablet with care to prevent accumulation of dirt and fingerprints on the surface.

CALIBRATION FREQUENCY

Under normal operating conditions, the instrument calibration should be verified *once a week* by the following the Calibration Procedure.

CALIBRATION PROCEDURE

See illustrations on the following page for calibration adjustment locations and reference.

To verify calibration:

1. Null the instrument as described in *Nulling (Zeroing) Procedure* page
1. Center the “CAL” portion of step tablet under read head.
2. Press read button to measure step tablet.
3. Hold read button down until a stable reading is attained.
 - The “CAL” reading should be $\pm 0.02D$ of the “CAL” value marked on the step tablet.

If “CAL” reading is NOT within tolerance, calibrate instrument.

To calibrate instrument:

1. Center the “CAL” portion of step tablet under the read head .
2. Press **and** hold read button to measure the step tablet.
3. Use a small screwdriver or adjustment tool into hole on the right side of instrument, to engage the calibration adjustment (potentiometer).
4. With read button still depressed, adjust as necessary to within $\pm 0.02D$ of the “CAL” value marked on the calibrated step tablet.
 - Rotate counterclockwise to increase value, clockwise to decrease.
5. Remove step tablet and press read button to check null, re-null the instrument as necessary.
6. Repeat until the calibration value and null are within tolerance.

NOTE: Always return the step tablet to the plastic bag on inside front cover for protection.

Calibration

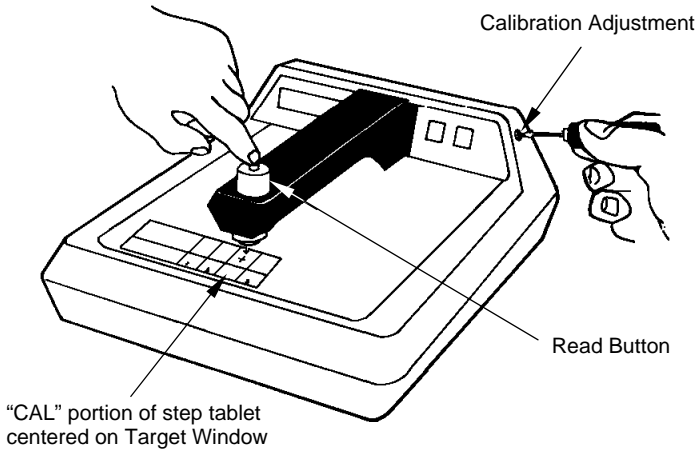

Figure 3. Calibration

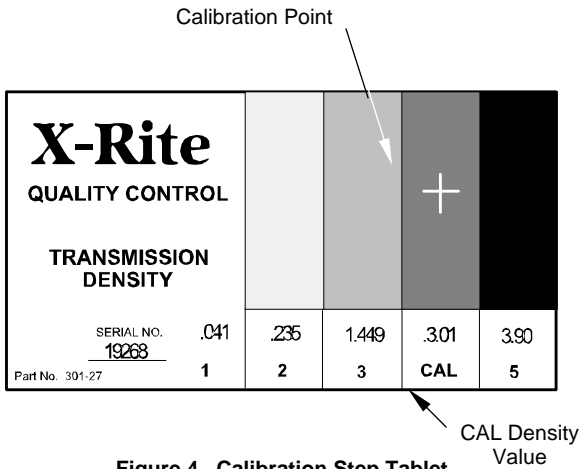

Figure 4. Calibration Step Tablet

MAINTENANCE

The 301 Densitometer is completely covered by a one (1) year warranty and should be referred to the factory or authorized service center for repairs within the warranty period. Attempts to make repairs within the warranty period may void the warranty. If repairs are needed after the warranty period, only qualified technicians should perform such repairs.

Refer to the exploded view illustration of the 301 on page 16.

WARNING: DISCONNECT POWER BEFORE PERFORMING ANY MAINTENANCE.

CLEANING

General cleaning of the 301 Densitometer should be done with mild a soap solution.

CAUTION: Do not use alcohol based solutions to clean light table.

Clean the instrument optics (apertures and read head opal glass) with a cotton swab moistened with alcohol. Remove residue and lint with lens paper. See Figure 5.

CAUTION: To prevent contamination of optics, always cover the reading area when cleaning the opal glass.

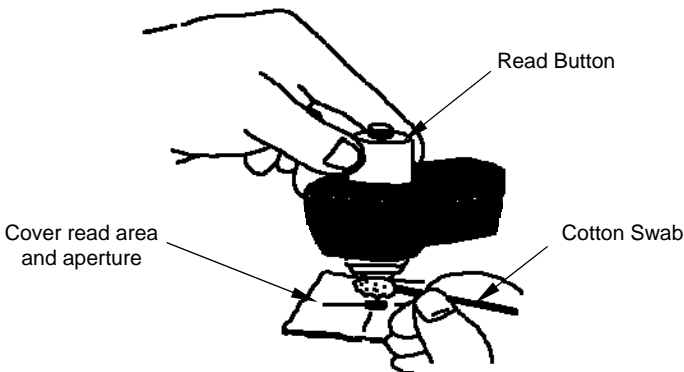

Figure 5. Cleaning Instrument Optics

Maintenance

FLUORESCENT BULB REPLACEMENT

Replace fluorescent bulbs as follows:

1. Remove four (4) screws securing light table to the unit chassis.
2. Remove light table.
3. Remove the faulty bulb(s) and replace with new, type F6T5/D fluorescent bulb(s).
4. Reinstall light table and secure to unit chassis with four (4) screws.

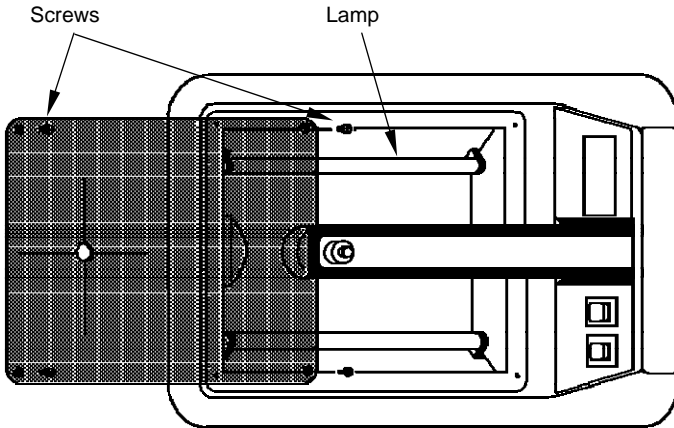

Figure 6. Fluorescent Bulb Access

READING LAMP REPLACEMENT (P/N 301-21)

Replace the reading area lamp as follows:

1. Remove the unit bottom cover by removing the four (4) screws located in the rubber feet.
2. Remove the four (4) screws securing the Lamp P.C. board to the arm assembly at bottom of chassis.
3. Disconnect lamp connector and remove faulty Lamp P.C. board.

NOTE: Ensure lamp P.C. board bulb is clean. Use alcohol on a lint free cloth or cotton swab to remove smudges.

CAUTION: The bulb on Lamp P.C. board has been prealigned for optimum optical performance. Use care not to bend or reposition the bulb when cleaning or installing.

4. Connect the lamp connector to new Lamp P.C. board.
5. Secure Lamp P.C. board to arm assembly with four (4) screws.
6. Reinstall bottom cover and secure with four (4) screws.

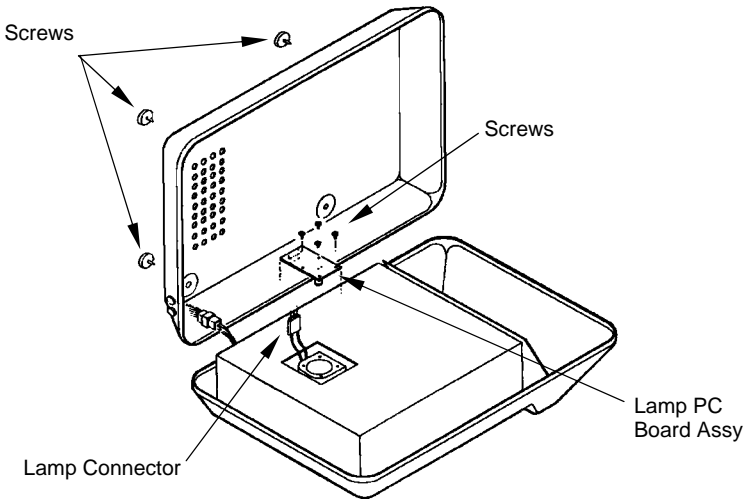

Figure 7. Lamp PC Board Access

Maintenance

FUSE REPLACEMENT

Replacement Fuse for 115VAC Instrument:

X-Rite P/N SE49-0050 (Time-delay 500ma-250V, 5mm x 20mm)

Replacement Fuse for 230VAC Instrument:

X-Rite P/N SE49-0040 (Time-delay 400ma-250V, 5mm x 20mm)

To replace fuse:

1. Turn power off (O) and remove detachable line cord.
2. Insert small flat-blade screwdriver into left edge of fuse carrier and pry out.
3. Remove blown fuse from carrier clip and discard.
4. Insert replacement fuse in fuse clip.
5. Reinsert fuse carrier into fuse cavity. Make sure carrier is firmly seated.
6. Reinstall detachable line cord.

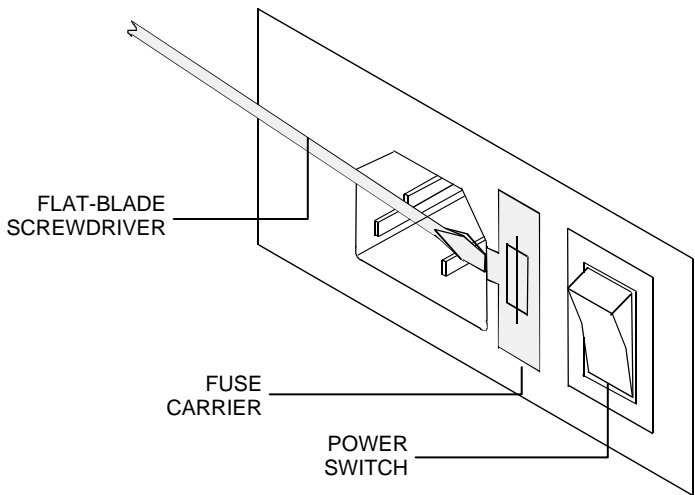

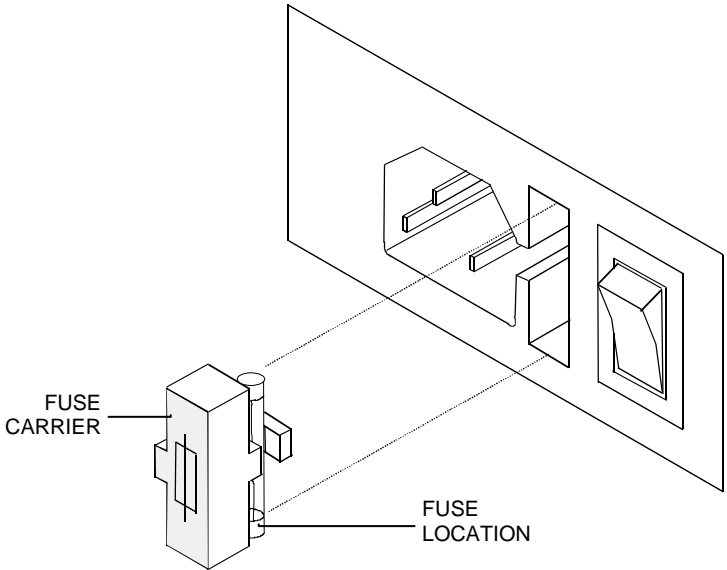

FACTORY REPAIR

X-Rite recognizes the need to provide complete technical repair service to customers. X-Rite provides repair of any 301 submitted past warranty. The customer shall pay shipping costs and the instrument shall be submitted in its original shipping carton as a complete unaltered unit.

TROUBLESHOOTING

The following chart is included for troubleshooting your 301 instrument. Use care to avoid danger of electrical shock when troubleshooting or performing any type of maintenance. Only qualified technicians should perform repairs.

WARNING: DISCONNECT POWER BEFORE REPLACING PARTS.

PROBLEM	CAUSE	REMEDY
Unit keeps blowing fuses (500ma for 301) (400ma for 301X)	Fuse loose in holder	Tighten fuse holder
	Short in p.c. board	*
	Short in wiring	*
	Short in ballast	*
	Short in transformer	*
Unit display will not turn on	Unit not nulled	Null unit
	Blown fuse	Replace fuse
	Loose connector(s)	Re-seat connector(s)
	Faulty P.C. board	*
	Faulty switch	*
	Bad transformer winding	*
Open wiring	*	
Light source will not illuminate	Blown fuse	Replace fuse
	Loose connector(s)	Re-seat connector(s)
	Faulty Lamp P.C. board	*
	Faulty switch	*
	Bad transformer winding	*
Open wiring	*	
Unit will not Null	Faulty light source	(See light source)
	Faulty P.C. board	*
	Faulty null switch	Replace switch
	Loose connector(s)	Re-seat connector
	Faulty sensor wiring	*
	Faulty sensor(s)	*
Fluorescent bulb(s) will not illuminate	Loose bulb(s)	Seat bulb(s)
	Blown fuse	Replace fuse
	Loose connector	Re-seat connector
	Faulty bulb(s)	Replace bulb(s)
	Faulty switch	*
	Faulty ballast(s)	*
	Open wiring	*
Reading will not change or hold	Loose connector(s)	Re-set connector
	Faulty P.C. board	*
	Faulty switch	*
	Open wiring	*

*Contact X-Rite Instrument Services or an authorized service center for repair.

OUTPUT CONNECTION (301RS)

The Model 301RS has the capability of sending measurement data to a printer, computer, or modem. This is done through the use of a RS-232 output connection located in the rear of the instrument. Data is sent each time the READ button is released.

RS-232 CONNECTION

Use a RS-232S type cable to connect the 301RS and the receiving device. The Transmit Function Switch, located inside the instrument, must be set to DTE (Data Terminal Equipment) or DCE (Data Communication Equipment) to correspond with the receiving device. The DTE setting sends the TRANSMIT signal through pin 2 and is normally used for printers or computers outputs. The DCE setting sends the TRANSMIT signal through pin 3 and is normally used for modem outputs.

NOTE: The output connection is preset from factory to DTE operation for *X-Rite 301* units and DCE operation for *Fuji 301* units.

To change the Transmit Function Switch setting:

1. Disconnect power to instrument.
2. Turn unit upside down and remove bottom cover by the four screws in located in the rubber feet.
3. Set the Transmit Function Switch to DTE for printer or computer connections or DCE for modem connections.
4. Return bottom cover in place and secure with four screws.

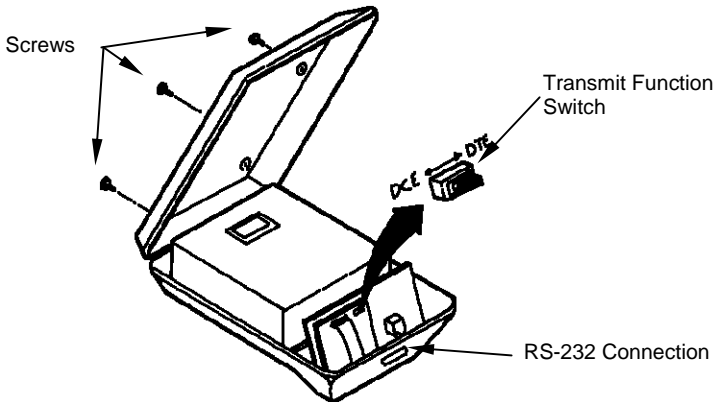

Figure 9. Transmit Function Switch Access

Output Connection

DATA INSTRUCTION FORMAT

Data is sent in the following format:

<Lead Character><Units><Tenths><Hundredths><Carriage Return>

Lead Character represents the ASCII code for a positive character (space) or negative character (-).

Units, Tenths, & Hundredths are three ASCII digits (0-9) representing density values.

Data is transmitted at the rate of 300 baud with one start bit and stop bit, and the parity bit set to logic zero.

Output logic level is -5Vdc to +5Vdc

DTE (Pin 2 = TRANSMIT)

DCE (Pin 3 = TRANSMIT)

Ground = Pin 7



Corporate Headquarters - USA

4300 44th St. SE
Grand Rapids, MI 49512
Phone 1 800 248 9748 or 1 616 803 2100
Fax 1 800 292 4437 or 1 616 803 2705

Corporate Headquarters - Europe

Althardstrasse 70
8105 Regensdorf
Switzerland
Phone (+41) 44 842 24 00
Fax (+41) 44 842 22 22

Corporate Headquarters - Asia

Room 808-810
Kornhill Metro Tower, 1 Kornhill Road
Quarry Bay, Hong Kong
Phone (+852) 2 568 6283
Fax (+852) 2 885 8610

Please visit www.xrite.com for a local office near you.