

**Model 408**

**Color Reflection  
Densitometer**

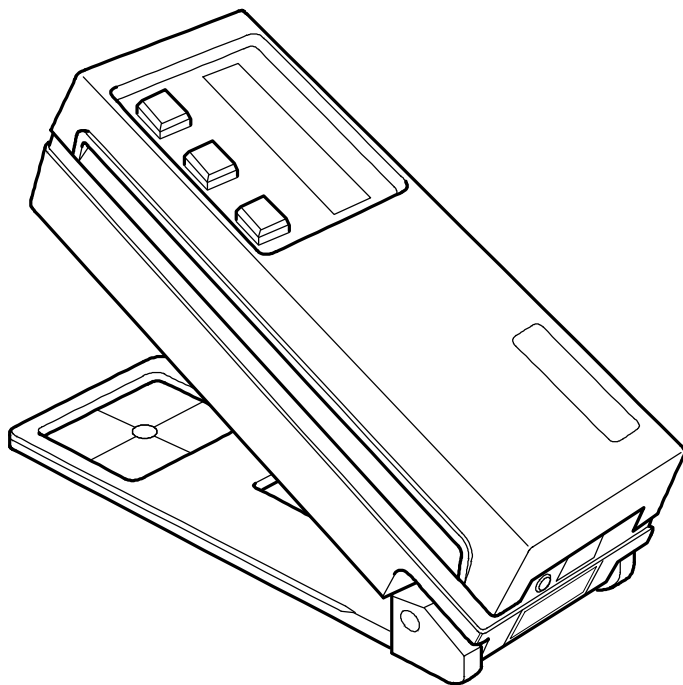

**Operation Manual**

**X-Rite** 



Dear Customer:

Congratulations! We at X-Rite, Incorporated are proud to present you with the X-Rite 408 Color Reflection Densitometer. This instrument represents the very latest in microcontrollers, integrated circuits, optics, and display technology. Your X-Rite 408 is a rugged, reliable, finely engineered instrument whose performance is unsurpassed.

To fully appreciate and protect your investment, we suggest that you take the necessary time to read and fully understand this manual. As always, X-Rite stands behind your 408 with a full one year limited warranty and a dedicated service organization. If the need arises, please don't hesitate to call us.

Thank you for your trust and confidence.

X-Rite, Incorporated

## **CE DECLARATION**

Manufacturer's Name: X-Rite, Incorporated  
Manufacturer's Address: 3100 44<sup>th</sup> Street, S.W.  
Grandville, Michigan 49418  
U.S.A.

Model Name: Densitometer  
Model No.: 408

Directive(s) Conformance: EMC 89/336/EEC LVD 73/23/EEC

---

**NOTE:** The device complies to the product specifications for the Low Voltage Directive when furnished with the 230VAC AC Adapter (X-Rite P/N SE30-62), and to UL Standards when furnished with the 115VAC AC Adapter (X-Rite P/N SE30-61).

---

# FEDERAL COMMUNICATIONS COMMISSION NOTICE

## FCC Statement

This equipment has been tested and found to comply with the limits for a Class A digital device, pursuant to Part 15 of the FCC Rules. These limits are designed to provide reasonable protection against harmful interference when the equipment is operated in a commercial environment. This equipment generates, uses, and can radiate radio frequency energy and, if not installed and used in accordance with the instruction manual, may cause harmful interference to radio communications. Operation of this equipment in a residential area is likely to cause harmful interference in which case the user will be required to correct the interference at his own expense.

## Canada

This Class A digital apparatus meets all requirements of the Canadian Interference-Causing Equipment Regulations.

Cet appareil numérique de la classe A respecte toutes les exigences du Règlement sur le matériel brouilleur du Canada.

The Manufacturer:	X-Rite, Incorporated
Der Hersteller:	3100 44th Street, S.W.
El fabricante:	Grandville, Michigan 49418
Le fabricant:	
Il fabbricante:	

Declares that:	Densitometer
gibt bekannt:	408
advierde que:	
avertit que:	
avverte che:	



is not intended to be connected to a public telecommunications network.  
an ein öffentliches Telekommunikations-Netzwerk nicht angeschlossen werden soll.  
no debe ser conectado a redes de telecomunicaciones públicas.  
ne doit pas être relié à un réseau de télécommunications publique.  
non deve essere connesso a reti di telecomunicazioni pubblici.

**CAUTION:** Operational hazard exists if AC adaptor other than X-Rite SE30-61 (115V) or SE30-62 (230V) is used.

**VORSICHT:** Betriebsgefahr besteht bei Gebrauch von anderen Adaptern als X-Rite SE30-61 (115 U) oder SE30-62 (230 U).

**AVISO:** No use otro adaptador C.A. que no sea la pieza X-Rite SE30-61 (115V) o SE30-62 (230V), por el riesgo de mal funcionamiento del equipo.

**ATTENTION:** Ne pas utiliser d'adaptateur autre que SE30-61 (115V) ou SE30-62 (230V) de X-Rite au risque de mauvais fonctionnement de l'appareil.

**AVVISO:** Non usare un altro adattatore C.A. che non è del pezzo X-Rite SE30-61 (115V) o SE30-62 (230V), per il rischio di malfunzionamento dell'apparecchio.

---

**NOTE:** Shielded interface cables must be used in order to maintain compliance with the desired FCC and European emission requirements.

**WARNING:** This instrument is not for use in explosive environment.

**WARNUNG:** Das Gerät darf in einer explosiven Umgebung NICHT verwendet werden.

**ADVERTENCIA:** NO use este aparato en los ambientes explosivos.

**ATTENTION:** Cet instrument NE DOIT PAS être utilisé dans un environnement explosif.

**AVVERTIMENTO:** NON usare questo apparecchio in ambienti esplosivi.

---

**USE ONLY:** AA NiCad batteries that are 600/700mAh rated, six required. Other types may burst causing personal injury.

**VORSICHT:** Verwenden Sie nur AA NiKad Akkus von 600/700mAh (Milliampere/Stunde) Nennstrom, 6 Stück erforderlich. Mit anderen Akkus besteht Explosions- und Verletzungsgefahr.

**ATENCION:** Use solamente las pilas de AA NiCad (se requiere seis) con condiciones de funcionamiento normales 600/700mAh (horas miliamperios). Es posible que los otros tipos puedan estallar y causar daños corporales.

**ATTENTION:** Utiliser seulement les batteries NiCad à courant nominal de 600mAh (milliampère/heure) (6 pièces nécessaire). Il y a danger d'explosion et de blessures avec les autres types.

**ATTENZIONE:** Usare solamente gli accumulatori al AA NiCad (si richiede sei) con le condizioni di funzionamento normali 600/700mAh (ore milliamperi). E possibile che altri tipi possano scoppiare e causare danno personale.

# Contents

<b>1</b>	<b>Overview and Setup</b>	
	Features .....	1-1
	Packaging and Parts .....	1-3
	Instrument Vocabulary .....	1-4
	Unlocking/Locking the Shoe .....	1-5
	Batteries and Power .....	1-6
	Adjusting the Display Angle .....	1-8
	I/O Port Setup .....	1-9
<b>2</b>	<b>Calibration</b>	
	Response Settings .....	2-1
	Overview of Calibration Procedures .....	2-3
	Long Calibration .....	2-4
	Color Correlation (CC) Calibration .....	2-7
	Quick-Cal™ .....	2-10
<b>3</b>	<b>Density Functions</b>	
	Selecting Density Function .....	3-2
	Selecting Density Mode .....	3-3
	Selecting Color Measurement Method .....	3-5
	Density Measurement .....	3-6
	Density Difference Measurement .....	3-8
	Miscellaneous Display Messages .....	3-10
<b>4</b>	<b>Dot Functions</b>	
	Dot Formula .....	4-1
	Selecting Dot Area or Dot Gain .....	4-3
	Selecting Measurement Method .....	4-4
	Dot Area Function .....	4-5
	Dot Gain Function .....	4-8
<b>5</b>	<b>Technical Information</b>	
	Serial Interface Information .....	5-1
	Instrument Specifications .....	5-4
	Accessories .....	5-6
	General Cleaning .....	5-7
	Optics Maintenance .....	5-7
	Target Window Replacement .....	5-8
	Lamp Replacement .....	5-9

**6 Appendices and Index**

Proprietary Notice .....6-1  
Limited Warranty .....6-2  
Index .....6-3

Copyright 1987, 1996 by  
X-Rite, Incorporated  
“ALL RIGHTS RESERVED”

X-Rite is a registered trademark and Quick Cal™, Q Cal™, Electronic Function Selection™, Computerized Color Response™, and CCR™, are trademarks of X-Rite, Incorporated. All other logos, brand names, and product names are the properties of their respective holders.



Features.....	1-1
Packaging and Parts .....	1-3
Instrument Vocabulary.....	1-4
Unlocking/Locking the Shoe .....	1-5
Batteries and Power .....	1-6
Adjusting the Display Angle .....	1-8
I/O Port Setup .....	1-9

The X-Rite 408 Color Reflection Densitometer is designed to meet the quality control needs of today's pressroom and graphic arts technicians. This completely portable instrument features different measurement modes for quickly measuring ink density, density difference, dot area, and dot gain. Measurements are taken with simple hand-held operation, and measurement data is clearly read on the interactive display. The three control buttons make measurement mode selection easy.

## FEATURES

The X-Rite 408 features several state-of-the-art technologies that place the instrument a step above competitive instruments in terms of accuracy, speed, and simplicity:

### **Computerized Color Response™ (CCR)**

The versatile 408 accommodates multiple status responses. Model 408G can take measurements using ANSI-Status T response, which is compatible with the GCA T-reference (T-Ref) standard. You can also select the traditional X-Rite graphic arts response, Status G. Model 408E features European Status E and Status I (displayed as N) responses.

### **QuickCal™ One-Step Calibration**

The 408's Quick-Cal feature makes calibration fast and easy. You simply select the "Q-Cal" mode on the instrument, then measure the white patch on the supplied calibration target card. You can also get complete agreement with other densitometers using the three-color response calibration.

### **Automatic On/Shut-Off**

To increase battery life, the 408 automatically turns itself off if it has not used within 45 seconds; and it automatically turns back whenever a key is pressed or measurement taken. Tests have shown that over 4,500 readings can be taken on one charge of new batteries.

### **Nonvolatile Memory**

A lithium battery stores calibration data and measured values when the densitometer's primary rechargeable batteries are depleted or removed.

### **Automatic Color Selection**

Equipped with Auto Color Select, the 408 eliminates manual rotation of a filter wheel and related erroneous measurements. All colors are measured simultaneously, then the correct reading is displayed in less than one second.

### **Additional Features**

- Large LCD display clearly identifies measurement data and mode function. No need for numeric codes to identify this information.
- Three large buttons place all function controls at operator's fingertips.
- Small 1.7mm aperture (GS or ES model) for reading reduced-size color bar patches.
- AC adapter is provided to allow readings while batteries are being recharged.
- Replaceable optics allow you to switch between "G" and "E" response.
- Two-way RS-232 interface operates at 1200 baud, or one of several other baud rates.

## PACKAGING AND PARTS

After removing the instrument from the shipping carton, inspect for possible damage. If any damage is noted, contact the transportation company immediately. Do nothing more until the carrier's agent has inspected the damage.

If damage is not evident, check to ensure that all items are included (refer to the parts list below).

### Your Package Should Include...

- 1 408 Color Reflection Densitometer
- 1 Carrying Case
- 1 Operation Manual
- 1 Color Reflection Calibration Reference;  
either 418-62 for Model 408 *or* 418/LP-62 for Model 408/LP
- 1 Warranty Registration Card
- 1 P/N SE30-61 Battery Charger, 115V  
*or* P/N SE30-62 Battery Charger, 230V
- 1 P/N SD01-41 Certificate of Calibration

Along with this Operation Manual, several important notices are included. You should read each of these notices before using the instrument.

### Return Packaging

Your X-Rite 408 was packaged in a carton specially designed to prevent damage. If re-shipment is necessary, the instrument should be re-packaged in the original carton. If the original carton is not available, a new one can be obtained from X-Rite.

### INSTRUMENT VOCABULARY

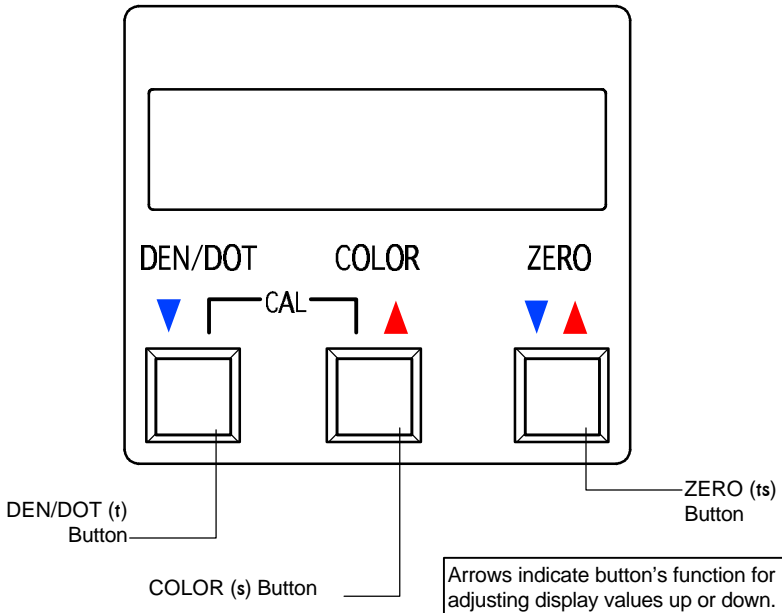
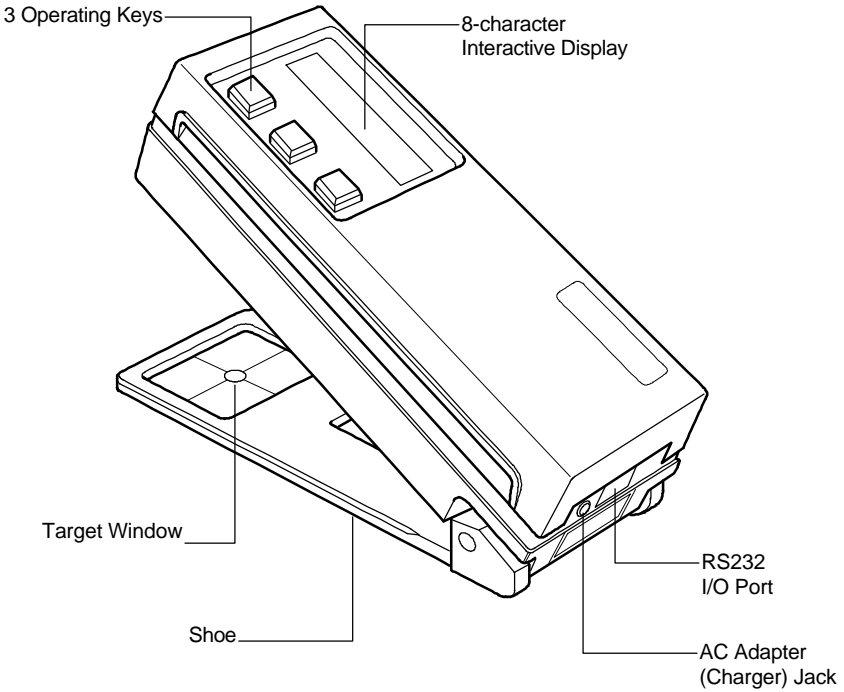

## UNLOCKING/LOCKING THE SHOE

To take measurements with the instrument, you must unlock the Shoe (see Instrument Vocabulary drawing in previous chapter). When the instrument is not in use, the Shoe should be re-locked to protect the instrument optics.

A sliding button on the bottom of the instrument locks the Shoe closed.

To unlock, hold Shoe against the unit and slide the lock button back until the button latch clears the Shoe tab. Carefully release the Shoe to open. (Figure 1-1)

To lock, hold the Shoe against the unit and slide the lock button forward until the button latch captures the Shoe tab. (Figure 1-2)

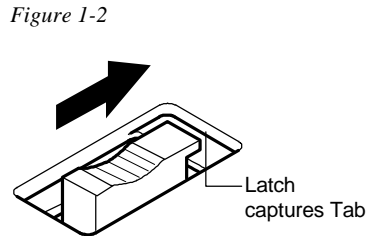
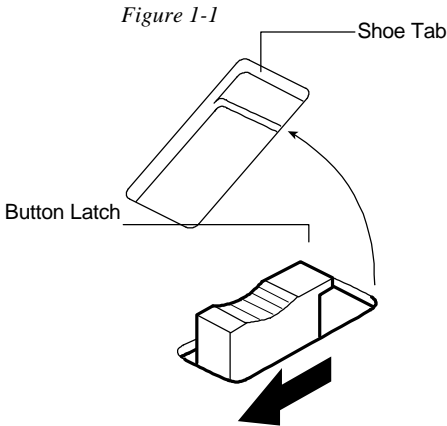

## BATTERIES AND POWER

Your 408 instrument's batteries should be charged before use. It can be operated while the batteries are being charged.

Before you begin charging, you must remove the battery isolation insert protruding from the battery cover. (Figure 1-3)

Figure 1-3

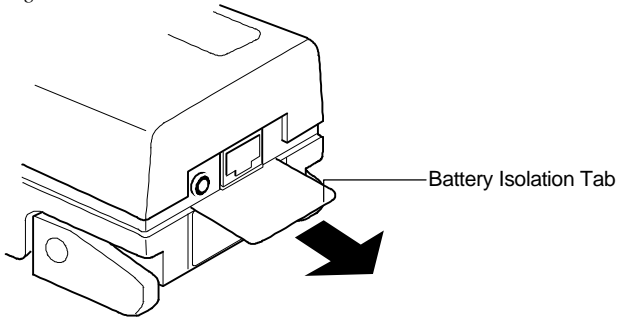

---

**NOTE:** Make sure the voltage indicated on the AC adapter complies with the AC line voltage in your area. If it does not, contact your X-Rite dealer.

---

To charge the battery:

1. Plug the AC Adapter Line Cord into the AC Adapter Jack on back of instrument. (Figure 1-4)
2. Plug AC Adapter into AC wall outlet.

You can use the instrument while it recharges. The instrument will be fully charged in approximately 14 hours.

Figure 1-4

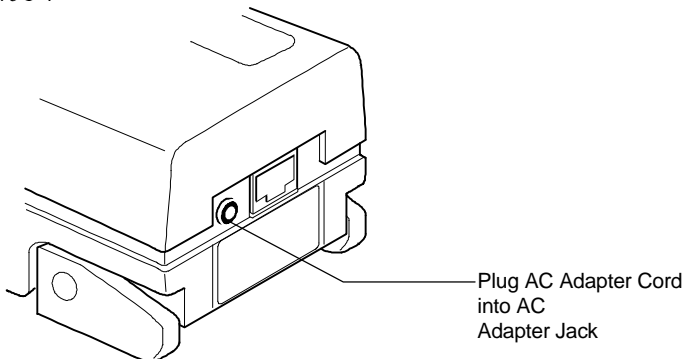

**NOTE:** If your unit has not been used for several weeks recharge for approximately 24 hours.

**NOTE:** When storing the unit for a long period of time, the batteries should be removed.

### Applying Power

The instrument remains “powered down” until a measurement is taken. When a measurement is taken, or when any key is pressed, the instrument automatically turns on.

If no measurements are taken or keys pressed for 45 seconds, the instrument automatically turns off again to conserve battery power.

### Inserting/Removing the Batteries

Your instrument is shipped with six AA NICAD batteries already installed. Should you ever need to replace the batteries, first close and lock the Shoe (when the shoe is unlocked and open, it blocks the battery door). Next, slide the battery door in the rear of the instrument down and off. The batteries will spring out a bit.

To replace the batteries, insert six fresh AA NICAD batteries into the instrument, three into each chamber. **Note the proper polarity of the batteries in Figure 1-5, and on the CAUTION label beneath the instrument.** You will need to press and hold the batteries down in place while you slide the battery cover back on. Push the cover into place until it is flush with the bottom of the instrument.

Figure 1-5

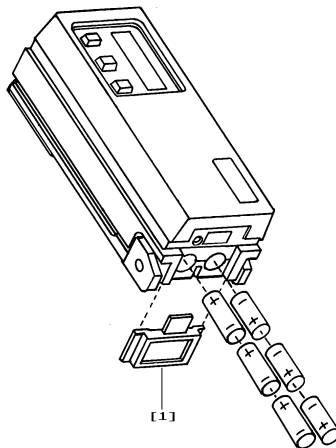

## ADJUSTING THE DISPLAY ANGLE

You can most clearly read the LCD display by viewing it at a 90° angle. The angle of the display can be adjusted to accommodate this for different user sight lines.

To adjust the display angle:

1. Set the Display Angle Adjustment Knob on the right side of the instrument to its midpoint setting. (Figure 1-6)

*Figure 1-6*

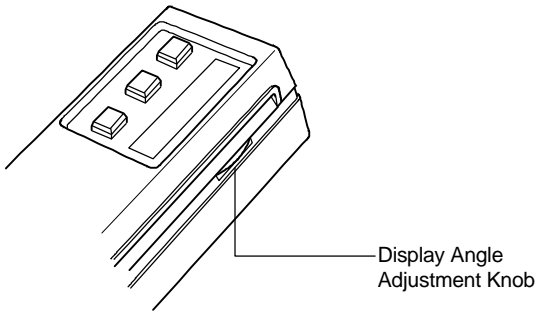

2. Activate the display by taking a measurement or pressing a control button.
3. Adjust the Display Angle Adjustment Knob until the displayed data can be most clearly seen from your line of sight.



## I/O PORT SETUP

Your X-Rite 408 has a serial port that allows data to be transmitted to—or received from—an external device. With this I/O connection made, the 408 can be controlled externally by Serial Input Commands.

If you do not plan to use the I/O port at this time, you can skip ahead to Chapter 2, “Calibration.”

You can configure different functions of your I/O port using the instrument’s MODE selection procedures. You can set up:

- The desired Baud rate (output rate of characters per second) for transmitting data via the I/O port;
- the desired header (HDR) that will appear above the transmitted or printed data; and
- the desired computer output format (COMP).

To set up the I/O port:

1. Press the DEN/DOT button and the COLOR button simultaneously, then release.

*N cal T Y* appears in the display, where “T” represents Status response (*T*, *G*, *E*, or *N*).

N cal T Y

2. Press DEN/DOT to indicate no, you do not want to calibrate. *N mode Y* appears in the display.

N mode Y

3. Press ZERO to indicate yes, you do want to set mode. *^ RESP T* appears in the display.

^ RESP T

4. Press DEN/DOT two times to advance the mode selection until *^ I/O Y* appears.

^ I/O Y

5. Press ZERO; *BAUD* plus a baud rate setting appears—either OFF, 300, 600, 1200, 2400, 4800, 9600. Press ZERO again to toggle to the next baud rate setting. Press repeatedly to toggle through all selections.

^BAUD 12>

6. When the desired baud rate setting appears, press DEN/DOT to select the setting. *HDR ON* or *HDR OFF* appears in the display.

HDR ON

7. Press ZERO to toggle to the desired setting, either *HDR ON* or *HDR OFF*.

—When *HDR ON* is selected, a header will appear above transmitted or printed data indicating the data type—either DEN (density) or DOT.

—When *HDR OFF* is selected, no header appears.

DEN  
C 1.24

EXAMPLE: Header On

C 1.24

EXAMPLE: Header Off

8. When the desired setting appears in the display, press DEN/DOT to select the setting. *COMP ON* or *COMP OFF* appears in the display.

COMP ON

9. Press **ZERO** to toggle to the desired setting, either *COMP ON* or *COMP OFF*.

—When *COMP ON* is selected, transmitted or printed data will simply be configured with single spaces between each measurement value.

—When *COMP OFF* is selected, transmitted or printed data will be configured in a “column” format, with a carriage return and line feed after each measurement value.

EXAMPLE: COMP On

DEN V0.67 C0.20 M1.23 Y0.77

EXAMPLE: COMP Off

DEN  
V0.67  
C0.20  
M1.23  
Y0.77

10. When the desired setting appears in the display, press **DEN/DOT** three times to select the setting and return to normal operation.

### RS232 Connector Interface

Your X-Rite 408 instrument can be connected to a computer or printer using a standard RS232 9-pin connector.

For more information on Serial Input Commands and remote control operation of the 408 contact X-Rite Technical Services.

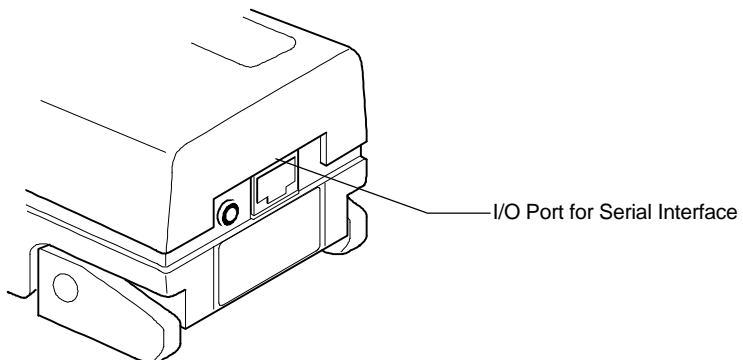



Response Settings.....	2-1
Overview of Calibration	
Procedures.....	2-3
Long Calibration .....	2-4
Color Correlation (CC)	
Calibration.....	2-7
Quick-Cal™.....	2-10

### Frequency of Calibration

Under long operating conditions, the instrument should be calibrated once per week, or whenever the instrument displays a message regarding calibration. You should perform a “long calibration” whenever possible. However, you can also perform a Quick-Cal™ procedure any time after an initial long calibration has been performed.

Before calibrating, you should determine the appropriate densitometer response setting for your instrument, based on your production control requirements.

### RESPONSE SETTINGS

A densitometer’s measurement system consists of several different components (lamp, optics, light sensor). Different densitometers consist of different types of these components. The density readings measured by these systems are called a *densitometer response*. Because components differ among densitometers, standard responses have been established in the industry. These standards ensure that even instruments with different components will measure in accordance with the same response.

With the complete set of optics—for version 408G and 408E—your versatile 408 instrument allows you to utilize four different densitometer response settings.

## Descriptions of Available Responses

Using 408G optics, your 408 instrument can use the following responses:

- **Status T—ANSI Status T Computerized Color Response** is wideband response most typically used in the North American graphic arts industry. This status is used to calibrate the instrument to the T-Ref™ color reference.
- **Status G—X-Rite Graphic Arts Response** is a wideband response that is similar to Status T, except that it is more sensitive to denser yellow inks.

Using 408E optics, your 408 instrument can use the following responses:

- **Status E—European** utilizes the Wratten 47B filter—for higher readings in yellow—instead of the Wratten 47 filter typically used in North America.
- **Status I (displayed as Status N)—Spectrodensitometric** response is computer corrected and designed for use with process inks on paper. Measurements other than process inks may produce measurement data with slight discrepancies.  
NOTE: The 408 displays this Status as Status *N*.

## Selecting Response

To select the appropriate response:

1. First, if this is your first time selecting response, you should plug your instrument in using its AC adapter. This will prevent the microprocessor from going into “sleep” mode to save battery power. With the instrument plugged in, you’ll be free to take your time learning this procedure.
2. Press the DEN/DOT button and the COLOR button simultaneously, then release.

*N cal T Y* appears in the display, where “T” represents Status T response. The instrument is preset to “T” at the factory.

**N cal T Y**

3. Press DEN/DOT to indicate no, you do not want to calibrate. *N mode Y* appears.

**N mode Y**

4. Press ZERO to indicate yes, you want to enter modes.  $\bar{\text{RESP}}$   $T$  appears.

$\wedge$ RESP T
-----------------

5. Press ZERO again, then again to toggle the Status selection between T and G (for 408G), or E and N (for 408E). Stop when the desired response is displayed.
6. Press DEN/DOT three times to return to the main display.

---

NOTE: Separate memory positions store calibration data for each of the four responses. If you change optics or change response setting, you must re-calibration using that response.

You do not need to re-calibrate when you switch to a response for which you have already calibrated.

---

## OVERVIEW OF CALIBRATION PROCEDURES

Calibrating your instrument is crucial to maintaining its measurement stability. It is also important to maintaining measurement agreement between several densitometers at the same site; and making all densitometers calibrate precisely to the same standard reference, such as T-Ref. Your 408 instrument's Computerized Color Response™ allows you to use one of three different calibrations procedures to address these factors:

1. Long Calibration allows you to calibrate your instrument to any color reference. This procedure will be used before you take your first measurements for each response. After this calibration procedure has been performed, you can use Quick-Cal™ (see below) to quickly re-calibrate when necessary.
2. Color Correlation Calibration allows you to set the 408 to measure in agreement with another densitometer that has the same response (for example, two wideband densitometers).
3. Quick Cal™ allows you to quickly re-calibrate to white without having to re-measure the black and/or color patches.



## LONG CALIBRATION

1. If this is your first time calibrating, you should plug your instrument in using its AC adapter. This will prevent the microprocessor from going into “sleep” mode to save battery power. With the instrument plugged in, you’ll be free to take your time learning this procedure.
2. Unlock the Shoe.
3. Press the DEN/DOT and COLOR buttons simultaneously until *N cal T Y* appears in the display. *T* stands for the default Status T Response; if you have a different response selected, its initial letter will appear in this position. (See “Selecting Response” earlier in this chapter.)

N cal T Y

4. Press ZERO to indicate Yes, you do want to calibrate.

N Qcal Y

5. Press DEN/DOT to select long calibration. *SET LO* appears in the display for a moment.

SET LO

6. At this point, refer to the front of your Color Reflection Reference Envelope. (Figure 3-1)

The first value that appears in the display should match the visual (“V”) value for the T Response printed on your envelope under:

STEP 1 (WHITE)	CAL-LO
T V0.07 C0.06 M0.08 Y0.13	
G V0.07 C0.06 M0.08 Y0.13	

Tv 0.07L

**NOTE:** Values shown above and in Figure 3-1 are examples—your values may be different.

Figure 3-1

**X-Rite®**  
 Color Reflection Reference  
 P/N 418-62  
 Serial No. C9647103S-35619

Polarization NOT INCLUDED

STEP 1 (WHITE)	CAL-LO
T V0.07 C0.06 M0.07 Y0.10	
G V0.07 C0.06 M0.07 Y0.10	
E V0.07 C0.06 M0.07 Y0.12	
I V0.07 C0.05 M0.07 Y0.12	
STEP 2 (GREY)	LINEARITY
V0.91	
STEP 3 (BLACK)	CAL-HI
V1.92	
STEP 4 (CYAN)	CAL-HI
T C1.35	
G C1.35	
E C1.35	
I C1.39	
STEP 5 (MAGENTA)	CAL-HI
T M1.60	
G M1.60	
E M1.60	
I M1.73	
STEP 6 (YELLOW)	CAL-HI
T Y1.31	
G Y1.50	
E Y1.80	
I Y1.83	

IMPORTANT! The density values on this reference are affected by its cleanliness. Higher densities are dramatically affected by smudge marks, dust, and fingerprints. Use a clean, lint-free cloth to clean the reference. Place it in the envelope when not in use.

- If the values on the envelope and on the display do not match, enter the correct value using the blue and red arrow buttons.

To lower the value:

Press and hold the ZERO (▼▲) button, then press DEN/DOT (▼) repeatedly to lower the value until the correct value is shown.

To raise the value:

Press and hold the ZERO (▼▲) button, then press COLOR (▲) repeatedly to raise the value until the correct value is shown.

---

TIP: If you need to move the value up or down by a large amount, hold the (▼▲) button and (▼) or (▲) button down. The numbers will advance faster as you hold it down.

---

- Release all buttons, then press COLOR. The T Response value for cyan (C) appears. It should match the value printed on your Reference Envelope.

STEP 1 (WHITE)			CAL-LO	
T	V0.07	C0.06	M0.08	Y0.13
G	V0.07	C0.06	M0.08	Y0.13

Tc 0.06L

- If the values on the envelope and on the display do not match, use the blue and red arrow buttons as specified in #7 to enter the correct value.
- Follow #8 again for magenta (M), and then again for yellow (Y). If the envelope and display values do not match for either color, follow #7 to correct.
- Press COLOR again. *SET HI* appears for a moment. Then, the Step 3 (Black) CAL-HI value for the T Response appears. (Figure 3-1)

SET HI

Tv 1.92H

- If the values on the envelope and on the display do not match, use the blue and red arrow buttons as specified in #7 to enter the correct value.
- Repeat #11 for Step 4 (cyan), Step 5 (magenta), and Step 6 (yellow). Follow #7 if you need to correct the values. (Figure 3-1)

14. Press COLOR again. *READ WHT* appears.

READ WHT

15. Take your Color Reflection Card out of the envelope. Lay it on a flat, steady surface with the color target side facing up. (Figure 3-2)

Figure 3-2

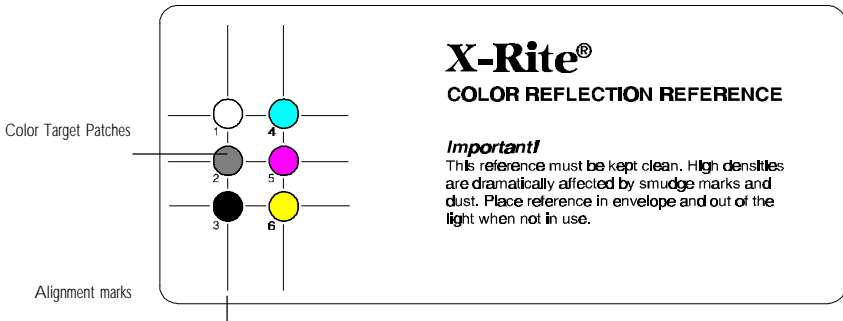

16. Read Step 1—the white target patch—by placing the instrument target window crosshairs over the alignment marks, then lowering the head down onto the shoe. One of the filter values for Step 1 appears in the display, then *READ BLK* (BLACK) appears.

V 0.06L

READ BLK

17. Read Step 3—the black target patch (*not* Step 2, the gray patch). One of the filter values for Step 3 appears in the display, then *READ CYAN* appears.
18. Repeat these measurement steps for Step 4 (cyan), Step 5 (magenta), and Step 6 (yellow).

The values that appear for each Step measurement should match the values listed on the envelope for that Step. If they do not, repeat the calibration procedure. If discrepancies continue to exist, contact X-Rite Instrument Services.

If all values were correct, your instrument is calibrated!

If you wish to calibrate to make your instrument measure in agreement with another instrument, perform the following procedures for “Color Correlation Calibration.”

## COLOR CORRELATION (CC) CALIBRATION

There are two ways to perform color correlation calibration, which creates measurement agreement between your 408 and another, similar instrument. The method you use depends on the type of calibration reference used by the other instrument.

---

NOTE: Color correlation between two instruments can best be achieved between two very similar instruments—two that utilize the same Status setting, have the same optics type, aperture size, and polarization (both have—or both do not have—polarization filters).

---

If the other instrument uses a reference similar to the 408's—with black, white, cyan, magenta, and yellow ink targets on paper—then use the first set of instructions. If the other instrument uses a reference without CMYK patches—such as a ceramic plaque with white and black only—then use the second set of instructions.

### CC Using Master Instrument CMYK Target

1. Calibrate the other, “master” instrument according to its manufacturer’s specifications and instructions.
2. Begin a long calibration procedure for your 408 instrument (see previous section).
3. When you go to verify the calibration values on the calibration reference envelope, *use the values for the master instrument’s calibration standard, instead.* Use the procedure in #7 of the long calibration instructions to modify the values on your instrument display to match those on the master instrument’s envelope or reference.
4. When calibration is due for either instrument, use *the master instrument’s calibration reference.*

**CC with No Master Instrument CMYK Target**

1. Get a pen or pencil and piece of paper ready.
2. Calibrate the master instrument according to its manufacturer's specifications and instructions.
3. Prepare the master instrument to read low density (white CAL-LO).
4. Measure Step 1 (white) on the 408's calibration reference using the master instrument. *Write down* the low density values for visual, cyan, magenta, and yellow.
5. Prepare the master instrument to read high density (black CAL HI).
6. Measure Step 3 (black) on the 408's calibration reference using the master instrument. *Write down* the high density values for visual, cyan, magenta, and yellow.
7. Prepare the master instrument to read color patches.
8. Read Steps 4, 5, and 6 (cyan, magenta, and yellow) on the 408's calibration reference using the master instrument. *Write down* the density values for each color.
9. Begin a long calibration using your 408 instrument. When you go to set the CAL LO values, verify the visual, cyan, magenta, and yellow values against the low density values you measured with the *master instrument*. Use the arrow buttons to adjust the values (see #7 of the last section).
10. Press COLOR again to advance to setting the CAL HI values. Verify the visual, cyan, magenta, and yellow values against the high density values you measured with the *master instrument*. Use the arrow buttons to adjust the values (see #7 of the last section).
11. When you enter the last "CAL HI" value, the instrument recognizes that you have entered measured black values for each color filter. *N col- Y* appears in the display, asking if you wish to perform a color correlation calibration.
12. Press COLOR to indicate yes, you do want to perform a color correlation calibration.

## 408 Color Reflection Densitometer

13. *SET cmy* appears briefly in the display, followed by the CAL-HI value for cyan. Verify the cyan value against the cyan value you measured with the *master instrument*. Use the arrow buttons to adjust the value (see #7 of the last section).
14. Verify the magenta and yellow values against the values measured with the master instrument, then adjust the values to match the master values as necessary.
15. *READ WHT* appears in the display. Measure white, then verify that the value matches the values recorded for each master instrument measurement. The display prompts you to measure Steps 3, 4, 5, and 6. Verify that these values match the master instrument's measurements, as well.
16. Perform future calibrations of your 408 using this procedure.

## QUICK CAL™

Once you have performed the long calibration, you can simply perform the Quick Cal™ procedure periodically to set the low density (white) value.

---

NOTE: In most cases, you should simply perform an entire long calibration if possible.

---

1. Press **DEN/DOT** and **COLOR** simultaneously, then release. *N cal T Y* appears in the display. T stands for the default Status T Response; if you have a different response selected, its initial letter will appear in this position. (See “Selecting Response” earlier in this chapter.)
2. Press **ZERO** to indicate yes, you do want to calibrate.
3. Press **ZERO** to select Quick Cal™ procedure.
4. Read Step 1—the white patch—on the reference card.

Your instrument is calibrated!

## Display Messages

If any display messages that have not been covered in this chapter appear during any of the calibration procedures, see “Miscellaneous Display Messages” at the end of Chapter 3 for an explanation and instructions.





Selecting Density Function .....	3-2
Selecting Density Mode .....	3-3
Selecting Color Measurement Method .....	3-5
Density Measurement .....	3-6
Density Difference Measurement .....	3-8
Miscellaneous Display Messages .....	3-10

Your 408 instrument can be used for density measurement functions; and for dot area and dot gain measurement functions. This chapter covers density functions, and the next chapter covers dot functions.

For density measurement, you need to set some measurement parameters. You need to select:

- the desired measurement *function* (density) (page 3-2);
- the desired density measurement *mode*—absolute density, or density minus paper (page 3-3); and
- the desired color measurement *method*—*SINGLE*, *AUTO*, or *ALL* (page 3-5).

These parameters must be set for all types of density measurement.

Once these parameters are set, you can set your instrument to evaluate measurement data two different ways:

- As a straight *density measurement* data. Viewing this data requires no additional setup (page 3-6).
- or*
- As a *density difference measurement* data. This data shows you the amount of difference between the measured density and a pre-set reference density. To view data in this format, you need to establish a reference measurement, and set up the instrument for density difference readings (page 3-8).

## SELECTING DENSITY FUNCTION

1. If this is your first time selecting a measurement function and mode, you should plug your instrument in using its AC adapter. This will prevent the microprocessor from going into “sleep” mode to save battery power. With the instrument plugged in, you’ll be free to take your time learning this procedure.
2. Next, make sure you have the desired response setting selected, and that the instrument is properly calibrated. These procedures are covered in the previous chapter, “Calibration.”
3. To select the measurement method for measuring ink density, press the DEN/DOT button repeatedly until *DEN* appears in the display (each time you press the button the display toggles between *DEN* and *DOT AREA* or *DOT GAIN*).

**DEN**

Now, you can choose to measure *absolute density*, which will read the ink density *including* the paper; or to measure density *minus paper*.

You make this selection by setting density mode.

## SELECTING DENSITY MODE

1. Press the DEN/DOT button and the COLOR button simultaneously, then release.

*N cal T Y* appears in the display, where “T” represents Status response you selected (*T*, *G*, *E*, or *N*).

N cal T Y

2. Press DEN/DOT to indicate no, you do not want to calibrate. *N mode Y* appears in the display.

N mode Y

3. Press ZERO to indicate yes, you do want to set mode.  $\bar{\text{RESP T}}$  appears in the display.

^ RESP T

4. Press DEN/DOT to advance to mode selection. *DEN-P* or *DEN AB* appears in the display.

DEN AB

5. Here is where you select *density minus paper* or *absolute density*.

If you wish to select *density minus paper*, press ZERO until *DEN-P* appears in the display. Then, simply press DEN/DOT three times to exit mode selection. Density minus paper mode is already selected; *DEN-P* appears in the display briefly, followed by *PAPER*.

If you wish to select *absolute density*, press ZERO until *DEN AB* appears in the display. Then, simply press DEN/DOT three times to exit mode selection. Absolute density mode is already selected; *DEN AB* appears in the display briefly, followed by a color value for visual, cyan, magenta, or yellow.

Measurement mode is now selected. Absolute density measurement data will appear with a “D” after the value; Density minus paper data will appear with an underlined “D” (D).

]v 0.13D

Indicates absolute density

]v 0.13(D

Indicates density minus paper

### Measuring PAPER for DEN-P Mode

When you select *density minus paper* as the measurement mode, you must provide a reading of the paper before taking color measurements. The instrument will take the density value of the paper and automatically subtract it from subsequent color measurements. This paper value must be updated before every measurement sequence.

Once *density minus paper (DEN-P)* mode is selected, *PAPER* appears in the display. Center the instrument target window over a sample of the paper, then lower the instrument head to take a reading and hold.

PAPER

- If the instrument recognizes the measurement as a paper reading, the display becomes ready for the first color reading.
- If the instrument does not recognize the measurement as a paper reading, *PAPER? Z* appears.

PAPER? Z

Keep the instrument pressed down, then press **ZERO** to indicate that yes, this is the new paper value. Then, the display becomes ready for the first color reading.

]v 0.13(

## SELECTING COLOR MEASUREMENT METHOD

You can choose from three different measurement methods using the density function:

- *SINGLE* measurement method simply measures and updates the specific color you selected.
- *AUTO* measurement method measures all four colors, then simply updates and displays the most dominant color.
- *ALL* measurement method measures and updates all four colors, and displays the most dominant color.

To select color measurement method:

1. Press DEN/DOT until *DEN* appears in the display. After a moment, the CAL LO value for one of the colors-visual (*v*), cyan (*c*), magenta (*m*), or yellow (*y*)-appears in the display.

v 0.13(

2. Press and hold COLOR. One of the color measurement methods-*SINGLE*, *AUTO*, or *ALL*-appears in the display. If the method you want appears, simply wait a moment and the color values will appear again.

S I N G L E

3. If you wish to change the color measurement method, press COLOR again, then again to toggle from one method to the next. When the desired method appears, simply wait a moment and the color values will appear again.

Color measurement method is set.

### Determining which Method is Active

The active color measurement method is indicated at the far left when color measurement information appears in the display:

- When *SINGLE* is active, no characters are shown at the far left.
- When *AUTO* is active, the characters “A” and “u” appear to the far left of the display .

[v 0.13(

]v 0.13(

- When *ALL* is active, the characters “A” and “ll” appear to the far left of the display.

## DENSITY MEASUREMENT

So far, you have performed the procedures to select density function, mode, and color measurement method.

You are now ready to begin taking measurements to check density values on your press sheet color bar. The type of measurement data that will be displayed will depend on the way you set up your instrument earlier in this chapter. However, for all functions, modes, and methods, the measurement technique is the same. Simply:

1. Center target window over area to be measured.
2. Lower unit to target window and hold closed.
3. Once measurement data is displayed, release the unit.
4. Measurement data will appear either as a normal density value (absolute or minus paper) or difference value.

### Viewing Density Measurement Data

There are several different combinations of mode and method settings that will affect the way the measurement data is displayed. Since you just set up these parameters yourself, you should see the data in the format you expect. For example, if you set your instrument parameters to *AUTO* and *-PAPER*, your measurement data will appear like this:

[c 1.13(
----------

“A” and “u” appear to the far left, indicating that the instrument automatically recognized the color—in our example, the color was cyan. And, the “D” after the value will underlined for density minus paper measurements; not underlined for absolute density measurements.

### Viewing Measurement Data for Each Color

You can view measurement data in the display for one color at a time. To toggle the display view from one color's measurement data to the next, press the COLOR button when data is displayed. Each time you press, the display switches from visual to cyan to magenta, and so forth.

[v 1.13(

[c 1.17(

[m 1.18(

[y 1.02(

EXAMPLE: Pressing the COLOR button repeatedly toggles display from one color's measurement data to the next.

If you are using the SINGLE or AUTO measurement method, the data displayed for each color represents the last time that color was measured. If you are using the ALL method, each color's data represents the amount of that color measured in the last color read. The most dominant color will have the highest density reading.

]v 0.67D

]c 0.20D

]m 1.23D

]y 0.77D

EXAMPLE: Using the ALL measurement method, all color data is derived from the single most recent measurement. In our example, magenta is the most dominant color.

## DENSITY DIFFERENCE MEASUREMENT

Density difference measurement uses the same parameters as density measurement. To set up for density difference measurement, follow the procedures earlier in this chapter for selecting density function, mode, and color measurement method.

To view measurement data as a density difference value between a measured sample and a known reference-instead of the density value of the measured sample-you must first enter a reference measurement; and then activate the density difference (*DEN-R* or *DEN-P-R*) display format.

### Entering a Reference Measurement

1. Press **DEN/DOT** until *DEN* appears in the display. After a moment, a color value for one of the colors appears in the display.
2. Press **ZERO**. *REF* appears for a moment, followed by the current Reference value. If none has been entered, the Reference value is *0.00*.
3. To enter a reference value-or change the current reference value-you can either:
  - measure the reference value directly; or
  - manually enter the reference value using the arrow button functions.

To measure the reference value directly:

Measure the color that you wish to use as the reference. Then, press **DEN/DOT** to return to normal operation.

To enter the reference value manually:

Hold down the **ZERO (ts)** button, then press the **DEN/DOT (t)** or **CAL (s)** button to adjust the value until the desired value is shown. Then, press **DEN/DOT** to return to normal operation.

---

**TIP:** If you need to move the value up or down by a large amount, hold the arrow button down. The numbers will advance faster as you hold it down.

---



## Activating Density Difference Display Format

Once you have your reference measurement established and stored in the instrument's memory, you now simply need to activate the density difference display format:

1. When you press DEN/DOT and *DEN* or *DEN-P* appears, press ZERO before the display switches to *PAPER* or the first color value.  
  
-R is added to the function. The display reads either *DEN-R* if you are in *absolute* mode; or *DEN-P-R* if you are in *minus paper* mode.
2. To de-activate density difference display format, repeat #1 to remove -R from the function.

## Viewing Density Difference Measurement Data

There are several different combinations of mode and method settings that will affect the way the measurement data is displayed. Since you just set up these parameters yourself, you should see the data in the format you expect. For example, if you set your instrument parameters to *AUTO* and *-PAPER*, your measurement data will appear like this:

[c -0@13(

“A” and “u” appear to the far left, indicating that the instrument automatically recognized the color—in our example, the color was cyan. And, the “D” after the value will be underlined for density minus paper measurements; not underlined for absolute density measurements. The “r” above the decimal point indicates that this is a density-minus-reference measurement.

A “negative” value indicates that the sample was measured to have less density than the reference. If a positive value appears, the sample was measured to have more density than the sample. If 0.00 appears, the sample was measured to have the same density as the reference.

## MISCELLANEOUS DISPLAY MESSAGES

During normal operation, some additional display messages may appear. Following are these messages, what these messages mean and what action must be taken when they appear.

*BAT LO* indicates that the batteries are getting low and will soon need to be charged. *BAT LO* only appears while the measurement is in progress. Once *BAT LO* is displayed, you will have approximately 100-200 measurements remaining before charging is required.

*CHARGE* indicates that the batteries are too low to operate the unit and must be recharged. *CHARGE* does not appear until you begin the recharge cycle. Thereafter, the unit will be functional and all previous data will be accessible.

*D TOO HI* indicates density value measured is too high. Make sure you are measuring the right color for the measurement sequence and try again.

*D TOO LO* indicates density value measured is too low. Make sure you are measuring the right color for the measurement sequence and try again.

If *D TOO HIGH* or *D TOO LO* continues to appear, re-calibrate the instrument using long calibration (see Chapter 2).

*INVALID* When the unit is not held down long enough during a measurement, *INVALID* will display.

*LAMP FAIL* Measurement lamp has failed. The lamp should be examined and replaced. When this message occurs, you can get out of this condition (after replacing lamp) by pressing *DEN/DOT* then *COLOR* then *DEN/DOT* or waiting until unit powers down.

*MEM LOST* (Displayed only during power-up) Internal lithium battery is failing. Intermittent connection on Ni-Cad batteries.

Dot Formula .....	4-1
Selecting Dot Area or Dot Gain .	4-3
Selecting Measurement Method	4-4
Dot Area Function .....	4-5
Dot Gain Function .....	4-8

For dot measurements, you need to set some measurement parameters. You need to select:

- The desired formula for dot measurements—the Murray-Davies formula or the Yule-Nielson formula (page 4-1);
- the desired measurement *function*—dot *area* or dot *gain* (page 4-3); and
- the desired color measurement *method*—*SINGLE* or *AUTO* (page 4-4)
- NOTE: All dot function measurements are minus paper.

## SELECTING DOT FORMULA

Dot is calculated using either the Murray-Davies formula or the Yule-Nielson formula. The Murray-Davies simply calculates dot by comparing the density of the tint minus paper with the density of the solid minus paper. Your 408 defaults to the Murray-Davies formula for measurements.

The Yule-Nielson formula is similar to Murray-Davies, except that it allows you to compensate for the amount of light that is absorbed or “trapped” when a dot measurement is taken. This is done by first dividing the densities of the paper and the solid by an “n” factor. Using the Murray-Davies equation, your 408 instrument “n” factor is simply 1.00, so the paper and solid densities are not affected. Using Yule-Nielson, the paper and solid densities are multiplied by an “n” factor value that is based on the properties of the substrate material.

The Murray-Davies formula for calculating Dot is:

$$\text{Apparent Dot Area} = \frac{1 - 10^{-(D_t)}}{1 - 10^{-(D_s)}} \times 100$$

Where:  $D_t$  = Density of tint minus density of paper  
 $D_s$  = Density of solid minus density of paper

The Yule-Nielson formula for calculating Dot is:

$$\text{Apparent Dot Area} = \frac{1 - 10^{-(D_t)^n}}{1 - 10^{-(D_s)^n}} \times 100$$

Where:  $D_t$  = Density of tint minus density of paper  
 $D_s$  = Density of solid minus density of paper  
 $n$  = “n” Factor

### Selecting Murray-Davies Formula

If you wish to use the Murray-Davies formula, you do not have to make any modifications to the factory-preset mode settings. When Murray Davies is active, dot values are displayed as percentages, with a “%” sign.

If you set your instrument to use Yule Nielson mode by changing the “n” factor, you can return the instrument to Murray Davies mode by setting the “n” factor back to 1.00. Perform the following instructions for selecting Yule-Nielson to reset the “n” factor.

### Selecting Yule-Nielson

When you change the instrument’s “n” factor to a value other than 1.00, measurements are automatically calculated using the Yule-Nielson formula.

To change the “n” factor”:

1. Press the DEN/DOT button and the COLOR button simultaneously, then release.

*N cal T Y* appears in the display, where “T” represents Status response you selected (*T*, *G*, *E*, or *N*).



2. Press DEN/DOT to indicate no, you do not want to calibrate.



3. Press ZERO to indicate yes, you do want to set mode.  $\bar{\text{RESP}}$   $T$  appears in the display.

^ RESP T
----------

4. Press DEN/DOT three times to advance the mode selection until  $\bar{\text{N}}=1.00$  appears.

<N= 1.00
----------

5. Here is where you change the “n” factor to prompt Yule-Nielson mode.

Hold down the ZERO (ts) button, then press the DEN/DOT (t) or CAL (s) button to adjust the value until the desired value is shown.

The following table lists the approximate value you should set as the “n” factor when using Yule-Nielson mode to measure ink on various materials:

Material	“n” Factor
Uncoated Paper	2.7
Coated Paper	1.6-1.7
3M Transfer Key	1.9
DuPont Cromalin	2.6
3M Color Key	4.0
Agfa-Gevaert Gevaproof	1.4
Newsprint	2.5

---

TIP: If you need to move the value up or down by a large amount, hold the arrow button down. The numbers will advance faster as you hold it down.

---

To return to Murray-Davies mode, use these procedures to re-set the “n” factor value back to 1.00.

6. Press DEN/DOT to return to normal operation. If you set a value other than 1.00 for the “n” factor, the instrument will use the Yule-Nielson formula to calculate dot.

## SELECTING DOT AREA OR DOT GAIN

1. If this is your first time selecting a measurement function, you should plug your instrument in using its AC adapter. This will prevent the microprocessor from going into “sleep” mode to save battery power. With the instrument plugged in, you’ll be free to take your time learning this procedure.
2. Next, make sure you have the desired response setting selected, and that the instrument is properly calibrated. These procedures are covered in the previous chapter, “Calibration.”
3. To select the measurement method for measuring ink density, press the DEN/DOT button repeatedly until *DOT AREA* or *DOT GAIN* appears in the display (each time you press the button the display toggles between *DEN* and *DOT AREA* or *DOT GAIN*).

**DOT AREA**

**DOT GAIN**

4. If DOT AREA appears and you wish to select DOT GAIN, press and release the ZERO button to toggle the selection. Do the same if DOT GAIN appears and you wish to select DOT AREA.

## SELECTING COLOR MEASUREMENT METHOD

You can choose from two different measurement methods using the dot function:

- *SINGLE* measurement method simply measures and updates the specific color you selected.
- *AUTO* measurement method measures all four colors, then simply updates and displays the most dominant color.
- NOTE: *ALL* is not used for dot measurements.

To select color measurement method:

1. Press **DEN/DOT** until *DOT AREA* or *DOT GAIN* appears in the display. After a moment, *PAPER* appears in the display.
2. Press **ZERO**. A dot area or dot gain value for one of the colors—visual (*v*), cyan (*c*), magenta (*m*), or yellow (*y*)—appears in the display.

[c 100 %]

3. Press and hold **COLOR**. One of the color measurement methods—*SINGLE* or *AUTO*—appears in the display. If the method you want appears, simply wait a moment and the color values will appear again.

SINGLE

3. If you wish to change the color measurement method, press **COLOR** again, then again to toggle from one method to the next. When the desired method appears, simply wait a moment and the color values will appear again.

Color measurement method is set.

### Determining which Method is Active

The active color measurement method is indicated at the far left when color measurement information appears in the display:

- When *SINGLE* is active, no characters are shown at the far left.
- When *AUTO* is active, the characters “A” and “u” appear to the far left of the display.

([v 0.13(

**DOT AREA FUNCTION**

Once dot area measurement (*DOT AREA*) mode is selected, *PAPER* appears in the display.

PAPER

- Center the instrument target window over a sample of the paper, then lower the instrument head to take a reading and hold.

—If the instrument recognizes the measurement as a paper reading, the display flashes *DOT T* (or *DOT G*, or *DOT E*, and so forth) momentarily, then becomes ready for the first *SOLID* reading.

—If the instrument does not recognize the measurement as a paper reading, *PAPER? Z* appears.

PAPER? Z

Keep the instrument pressed down, then press **ZERO** to indicate that yes, this is the new paper value. Then, the display becomes ready for the first *SOLID* reading.

[ SOLID

- Measure the solid patch. *DOT T* is displayed during measurement, then the measurement data appears.

DOT T

[m 1.57s

If Solid is displayed as a Dot value (a percentage, such as *m 94%*) instead of a solid density value (such as *m 1.57s*), hold the instrument closed and press **ZERO**.

If *SOLID? Z* is displayed, press **ZERO** to measure as a Solid, then release the instrument.

---

NOTE: Solid density is displayed minus paper.

---



3. Read a tint of the solid color you just measured. During measurement, *DOT T* is displayed. Then, the Dot value is displayed.

DOT T	[m 75 %
-------	---------

4. Measure additional tints of that color. The instrument automatically recognizes the measurements as tint values and displays the tint percentage.
5. When you are ready to measure another color, simply measure the solid and repeat the procedures beginning with #2. The instrument automatically recognizes the measurement as a solid. Also, you do not need to enter a new paper measurement.

### Display Messages

If any display messages that have not been covered in this chapter appear during any of the dot gain functions, see “Miscellaneous Display Messages” at the end of Chapter 3 for an explanation and instructions.

## DOT GAIN FUNCTION

Dot gain measurement compares the tint percentage of a color patch on paper to the intended tint percentage produced on the film.

Your instrument is preset at the factory to use the standard tint percentages for color bar patches as the four measurement reference values:

Factory presets for 408G    Factory presets for 408E

- Reference 1 (r1) is 25%                      —Reference 1 (r1) is 40%
- Reference 2 (r2) is 50%                      —Reference 2 (r2) is OFF
- Reference 3 (r3) is 75%                      —Reference 3 (r3) is 80%

Your first dot gain measurement compares the dot percentage of the measured patch to the first reference value (r1). The difference between the reference value and the measured value is calculated as dot gain—the amount the ink dots have spread on the paper.

If needed, you can adjust the Reference values to meet your specific needs. These procedures are covered next. If you wish to simply use the factory preset reference values, you can skip ahead to “Dot Gain Measurement.”

### Adjusting Dot Gain Reference Values

Once dot gain measurement (*DOT GAIN*) mode is selected, *PAPER* appears in the display.



1. Press **ZERO** two times. *REF* appears in the display momentarily, followed by one of the reference values—either r1, r2, or r3.

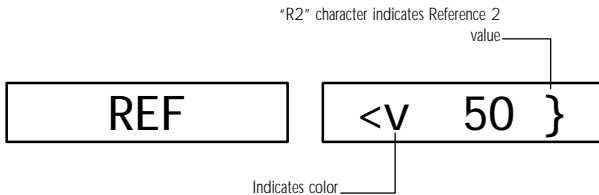

2. To select the desired color at the current reference value, press **COLOR** to toggle between *v*, *c*, *m*, and *y*. The factory presets should show the same value for each color. (You can enter a different value for each color if you like.)

- When the color and reference value you wish to change appear in the display, use ZERO (ts), COLOR (s), and DEN/DOT (t) buttons to adjust the value.

—Press and hold ZERO, then press COLOR (s) to raise the value;

—Press and hold ZERO, then press DEN/DOT (t) to lower the value.

When you change the preset values, they are turned “off.” Your new reference values can be set within the following ranges.

—r1 can be set between 1% and 45%.

—r2 can be set between 46% and 64%

—r3 can be set between 65% and 100%

These value ranges apply to 408G and 408E instruments.

- Advance to the next color, then repeat #3; or press ZERO to advance to the next reference value, either r1, r2, or r3.

<v	75	{
----	----	---

Repeat #3 and #4 until all reference values are set to your preferences.

- Press DEN/DOT to return to dot gain measurement mode. Measurements at each tint will be compared to the appropriate reference value.

**Dot Gain Measurement**

Once dot gain measurement (*DOT GAIN*) mode is selected, *PAPER* appears in the display.

PAPER

1. Center the instrument target window over a sample of the paper, then lower the instrument head to take a reading and hold.

—If the instrument recognizes the measurement as a paper reading, the display flashes *DOT T* (or *DOT G*, or *DOT E*, and so forth) momentarily, then becomes ready for the first *SOLID* reading.

—If the instrument does not recognize the measurement as a paper reading, *PAPER? Z* appears.

PAPER? Z

Keep the instrument pressed down, then press **ZERO** to indicate that yes, this is the new paper value. Then, the display becomes ready for the first *SOLID* reading.

[ SOLID

2. Measure the solid patch. *DOT T* is displayed during measurement, then the measurement data appears.

DOT T

[m 1.57s

If Solid is displayed as a Dot value (a percentage, such as *m 94%*) instead of a solid density value (such as *m 1.57s*), hold the instrument closed and press **ZERO**.

If *SOLID? Z* is displayed, press **ZERO** to measure as a Solid, then release the instrument.

---

NOTE: Solid density is displayed minus paper.

---

3. Read the first tint of the solid color you just measured. This should be the color patch with the lowest tint percentage, such as the 25% patch. During measurement, *DOT T* is displayed. Then, the Dot Gain value is displayed.

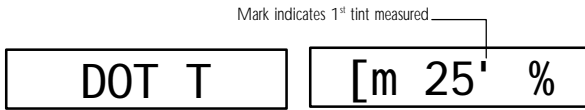

A mark before the percentage symbol indicates which tint percentage in the sequence has been measured.

4. Measure the remaining tints of that color. The instrument automatically recognizes the measurements as tint values and displays the dot gain value for that tint. Display marks indicate which tint percentage in the sequence has been measured.

2<sup>nd</sup> dot gain measurement



3rd measurement

### Display Messages

If any display messages that have not been covered in this chapter appear during any of the dot gain functions, see “Miscellaneous Display Messages” at the end of Chapter 3 for an explanation and instructions.



- Serial Interface Information .....5-1
- Instrument Specifications .....5-4
- Accessories .....5-6
- General Cleaning .....5-7
- Optics Maintenance.....5-7
- Target Window Replacement ....5-8
- Lamp Replacement .....5-9

## SERIAL INTERFACE INFORMATION

The connector used for serial input/output is a Modular 10 circuit type. Figure 5-1 is the connection diagram.

Figure 5-1

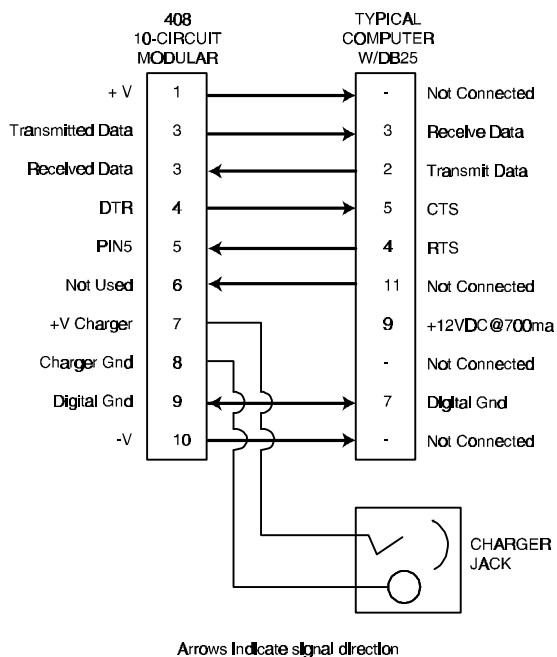

## 408 Color Reflection Densitometer

An RS232 to modular interface adapter is available from X-Rite which performs as shown in the diagram on the previous page. This adapter also provides a jack for the AC adapter so that only one cable need be connected to the 408. Also, when the adapter is not connected to the jack, the +V CHARGER is connected to pin 9 of the DB25 in the diagram. The charger ground is connected to the jack ground only.

The part numbers for these interface adapters are: P/N 418-70 (male DB25 connector) P/N 418-71 (female DB25 connector) See "Accessories" later in this chapter for other adapters.

A 10-foot modular to modular cable for connection of the 408 to the interface adapter is available by ordering P/N SE108-69.

### Term Definitions

Pin 2 Transmitted Data: Data transmitted from the densitometer with parameters (baud rate, format) set by the densitometer.

Pin 3 Received Data: Data received by the densitometer from outside source using the same parameters as the densitometer.

Pin 4 DTR (Data Terminal Ready): Logic 0 active (On Line) and Logic 1 during: Power Off, Power Up, Self Test, during measurements, and when serving RCI.

Pin 5 PIN 5 is set to CTS=logic 0 active; if set to BUSY=logic 1 active; and if set to OFF=ignored.

Pin 7: This pin is used for supplying 12VDC @ 700ma for charging the 408 without having the Adapter connected directly to the unit.

### Input Characteristics

Logic 1=+.8VDC to -25VDC

Logic 0=+2.25VDC to +25VDC

### Output Characteristics

Logic 1=approximately -4VDC

Logic 0 = approximately +5VDC

Outputs are @ 0VDC during Power Down.



A typical interconnection between the 408 and a computer—in its simplest form—is shown in Figure 5-2.

Figure 5-2

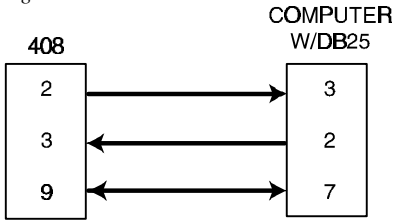

### Serial Output

The data format that is transmitted from the 408 is determined by the I/O PORT options found in Chapter 1 under “I/O Port Setup.”

Data transmitted by the 408 shall have one start bit (Logic 0), 7 bits of ASCII, one parity bit (set to Logic 0), and then one stop bit (Logic 1).

### Serial Input Commands

Your 408 is equipped with an input that allows the 408 to be controlled or monitored remotely. Every function that can be performed by the 408 (plus a few special functions not activated by the keyboard) can be activated via the serial input. This Remote Control Interface is covered by U.S. Patent 4,591,978.

For more information on Serial Input Commands and remote control operation of the 408, contact X-Rite Technical Services.

## **INSTRUMENT SPECIFICATIONS**

### **Display**

Dot Matrix LCD

### **Measuring Geometry**

ANSI PH 2.17/DIN 16536 multi-sensor array

### **Light Source**

Filament bulb 3000°K DIN approx. 2856°K ANSI

### **Receiver**

Silicon Photodiode

### **Color Response**

G optics for X-Rite Graphics Art Response w/ ANSI Status T  
Computerized Color Response.

E optics w/47B per DIN16536 w/Glass interference type  
Computerized Color Response.

### **Measuring Range**

0.00D-2.5D for G & E

0.00D-2.20D for GS,ES, G/LP, & E/LP

0-100% dot

### **Reproducibility**

$\pm 0.01D$

$\pm 1\%$  for dot area (10-100%)

### **Linearity**

$\pm 0.01D$  or  $\pm 1\%$

### **Inter-Instrument Agreement**

$\pm 0.02D$  or  $\pm 2\%$

### **Aperture Diameter**

408G,E—3.4mm

408GS,ES—1.7mm

### **Calibration**

Automatic with Quick Cal™

Adjusts Zero and Slope for Density

Computerized Color Response™

**Polarization Filter**

2 x linear /LP option

**Warm Up Time**

None

**Zero Stability**

$\pm 0.01D$  maximum per 8 hours

**Slope Stability**

$\pm 1\%$  maximum per year

**Power Supply**

Six rechargeable AA NiCad batteries 7.2v total rated @600m Ah (included)

**Charge Time**

Approximately 14 hours

**AC Adapter Requirements**

408 90-130VAC, 50-60Hz, 18W Maximum

408X 180-260VAC, 50-60Hz, 20W Maximum

12VDC @ 700ma, Positive tip

**Operating Temperature Range**

50°-104°F /10°-40°C

**Measurements Per Charge**

Approx. 4500 (usage dependent)

**Measuring Time**

Approximately 0.6 seconds

**Weight**

800 grams

**Dimensions**

7.4cm H x 8.cm W x 19.6cm L

## ACCESSORIES

### Accessories Included

Color Reflection Reference  
Operation Manual  
AC Adapter  
Carrying Case

Specifications and design subject to change without notice.

### Accessories and Replacement Parts Available

Polarization Filter .....P/N 418-73  
Security Cable .....P/N 418-75  
1.7mm Target Window..... P/N 418-21-017-KIT  
3.4mm Target Window..... P/N 418-21-034-KIT  
1.7mm Aperture .....P/N 418-63-017  
3.4mm Aperture .....P/N 418-63-034  
Lamp Assembly.....P/N 418-13  
G Optics..... P/N 418G-35  
G/LP Optics .....P/N 418G/LP-35  
GS Optics.....P/N 418GS-35  
E Optics ..... P/N 418E-35  
E/LP Optics.....P/N 418E/LP-35  
ES Optics ..... P/N 418ES-35  
Modular Interconnect Cable ..... P/N SE108-69  
DB25P DCE (Null Modem) Interface Adapter.....P/N 418-70  
DB25S DCE (Null Modem) Interface Adapter.....P/N 418-71  
DB25P DTE (Normal) Interface Adapter .....P/N 418-80  
DB25S DTE (Normal) Interface Adapter.....P/N 418-81  
DB9P Interface Adapter .....P/N 418-90  
DB9S Interface Adapter .....P/N 418-91  
Modular Interconnect Cable for Macintosh® computers  
with 8 pin mini-DIN connector.....P/N 418-79

For further information on accessories contact your X-Rite representative or call X-Rite, Inc. at: 1-888-826-3059.

## GENERAL CLEANING

The exterior of the instrument can be wiped clean with a cloth dampened in water or a mild cleaner whenever required.

---

NOTE: Do not use any solvents to remove ink from the cover.

---

## OPTICS MAINTENANCE

1. Remove Optics assembly by removing sensor nose screws from densitometer housing, and then lifting the assembly upward. (Figure 5-3)

Figure 5-3

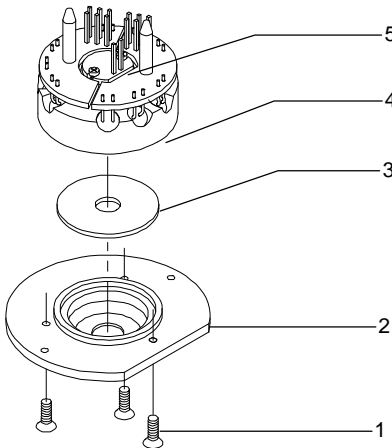

2. Remove three inner screws [1] on sensor nose [2] and rotate Optics over carefully so sensor nose [2] is at bottom.
3. Carefully lift up Optics assembly [4] separating from sensor nose [2].
4. Clean Optics sensors with camelhair brush and set aside.
5. Carefully remove IR Glass [3] and optional polarizing filter (if installed) from sensor nose [2].
6. Remove dust and lint from inner sensor nose and filter(s) with camelhair brush.

- Carefully reinstall optional polarizing filter (if used) and IR Glass [3] (holding both by edges) into sensor nose, making sure filter(s) are properly seated.
- Align flat edge of sensor nose [2] with flat edge on Lamp assembly P.C.B [5] and secure sensor nose [2] to Optics assembly [4] with three inner screws [1].
- Carefully reinstall Optics assembly into densitometer by facing flat edge of sensor nose to front of densitometer. Work into position until alignment pins and connector pins are properly seated.
- Insert and tighten sensor nose screws.

### TARGET WINDOW REPLACEMENT

- Remove old target window by pushing downward on top of shoe [1]. Clean off any remaining adhesive from shoe. (Figure 5-4)

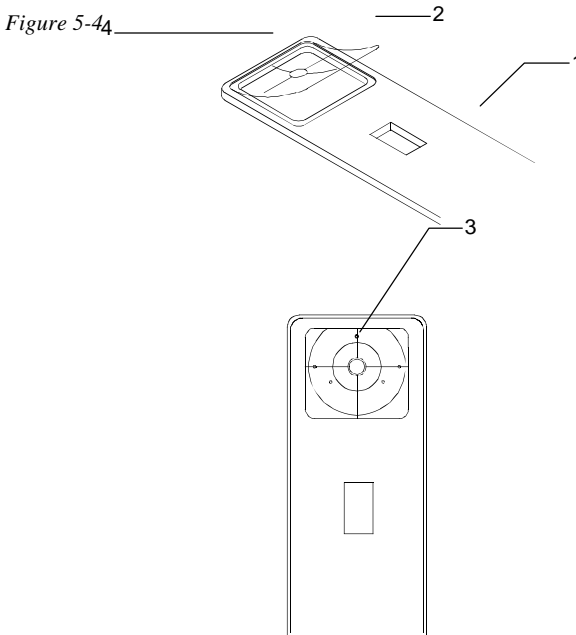

- Turn densitometer over and compress shoe [1] all the way down, and lock shoe.
- Remove paper backing from tape strip on new target window [2].

4. Place one taped edge of target window [2] on indent [4] at bottom of shoe [1].
5. Align hole of target window [2] exactly in center of hole in sensor nose [3] and press remaining three sides of target window into place.
6. Unlock shoe.

## LAMP REPLACEMENT

### Lamp Removal

1. Remove Optics assembly by removing sensor nose screws [1] from the densitometer housing, and then lifting assembly upward. **THE THREE INNER SCREWS ON SENSOR NOSE ARE NOT TO BE REMOVED.** (Figure 5-5)

Figure 5-5

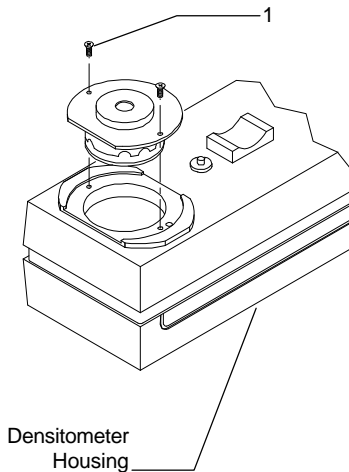

2. Once Optics assembly is free, rotate over and remove two screws [4] from the lamp PCB [3]. (Figure 5-6)

Figure 5-6

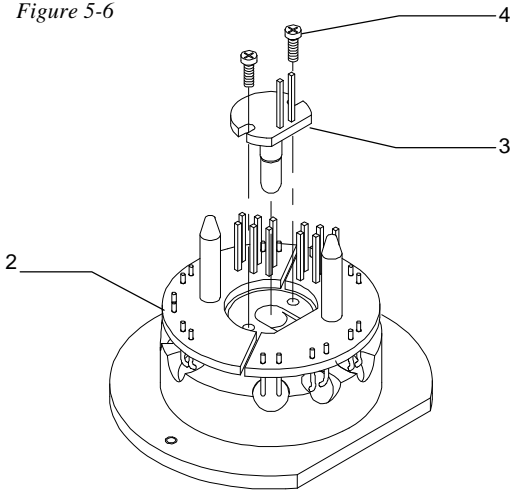

3. Carefully remove old Lamp assembly [3] by lifting upward and discarding.

### Lamp Installation

1. Align the flat edges of Optics PCB [2] and new Lamp PCB [3], and insert into Optics assembly. (figure 5-6)

---

**NOTE: EXTREME CAUTION MUST BE TAKEN WHEN INSTALLING NEW LAMP. DO NOT BEND LAMP LEADS.**

---

2. Insert and tighten the two lamp screws [4].
3. Carefully reinstall Optics assembly into densitometer by facing flat edge of sensor nose to front of densitometer. Work into position until alignment pins and connector pins are properly seated.
4. Insert and tighten sensor nose screws [1]. (Figure 5-5)



Proprietary Notice.....	6-1
Limited Warranty .....	6-2
Index .....	6-3

**PROPRIETARY NOTICE**

The information contained in this manual is derived from patent and proprietary data from X-Rite, Incorporated. This manual has been prepared solely for the purpose of assisting operation and maintenance personnel in their use and general maintenance of the X-Rite 408.

The contents of this manual are the property of X-Rite, Incorporated and are copyrighted. Any reproduction in whole or part is strictly prohibited. Publication of this information does not imply any rights to reproduce or use it for any purpose other than installing, operating, or maintaining the equipment described herein.

This instrument is covered by one or more of the following U.S. patents: #4,080,075; #4,591,978; #5,015,098; and patents pending. Foreign patent numbers provided on request.

## LIMITED WARRANTY

X-Rite, Incorporated warrants each instrument manufactured by them to be free of defects in material and workmanship for a period of 12 months. THERE ARE NO WARRANTIES OF MERCHANTABILITY OR FITNESS. THIS WARRANTY OBLIGATION IS LIMITED TO SERVICING THE UNIT RETURNED TO THE FACTORY FOR THAT PURPOSE AND EXCLUDES THE LAMP AND NICAD BATTERIES.

The instrument shall be returned with transportation charges prepaid. If the fault has been caused by misuse or abnormal operating conditions, repairs will be billed at a nominal cost. In this case, an estimate will be submitted before work is started, if requested.

A Warranty Registration Card is enclosed with each instrument. The purchaser should fill in the card completely and return it to X-Rite, Incorporated postmarked no later than ten (10) days from the date of receipt. This card registers your system with us for warranty coverage. Once your unit is registered, we are able to maintain a file to help expedite service in case it is needed.

Always include serial number and place of purchase in any correspondence concerning your instrument. The serial number is located at the rear of the instrument.

X-Rite, Incorporated offers a repair program for instruments out of warranty. For more information, contact X-Rite Technical Services Department.

This agreement shall be interpreted in accordance with the laws of the State of Michigan and jurisdiction and venue shall lie with the courts of Michigan as selected by X-Rite, Incorporated.

# Index

- A**ccessories, 5-6
- Adjusting the display angle, 1-8
- B**atteries and Power, 1-6, 1-7
- C**alibration, 2-13, 2-16
  - Color Correlation (CC) Calibration, 2-20
  - Long Calibration, 2-17
  - Quick Cal, 2-23
- Charging the battery, 1-6
- Cleaning, 5-7
- Color measurement method, 3-5
- D**ensity functions, 3-1, 3-2
  - Density difference measurement, 3-8
  - Density measurement. *See*
- Density mode, 3-3
- Display messages. *See*
- Dot functions, 4-1, 4-4
  - Dot area function, 4-6
  - Dot gain function, 4-8
- F**eatures, 1-1
- I/O** port setup, 1-9
- Instrument Vocabulary drawings, 1-4
- M**aintenance, 5-7—5-9
- Murray-Davies formula, 4-2
- P**ackaging and Parts, 1-3
- PAPER, 3-4
- Powering the Instrument, 1-6
- Q**uick Cal™, 2-23
- R**esponse settings, 2-13
- Responses, 2-14
- Return Packaging, 1-3
- RS232 connector interface, 1-11
- S**electing response, 2-14
- Serial interface information, 5-1
- Specifications, 5-4
- U**nlocking/Locking the Shoe, 1-5
- Y**ule-Nielson formula, 4-2



**X-Rite, Incorporated—World Headquarters**

3100 44th Street S.W. • Grandville, Michigan 49418 • USA

www.x-rite.com • (616) 534-7663

Toll-Free U.S. Numbers

Tel: 1-888-826-3059 • Fax: 1-888-826-3061

Toll-Free International Numbers

Tel: 1-888-826-3039 • Fax: 1-888-826-3041

**X-Rite GmbH**

Stollwerckstraße 32 • 51149 Köln • Germany

Tel: (49) 2203-91450 • Fax: (49) 2203-914519

**X-Rite GmbH**

Sochorova 705 • CZ-682 • 11 Vyskov • Czech Republic

Tel: (420) 507-328197 • Fax: (420) 507-328138

**X-Rite Asia Pacific Ltd.**

Room 808-10 • Kornhill Metro Tower • 1 Kornhill Road • Quarry Bay

Hong Kong • Tel: (852) 2-568-6283 • Fax: (852) 2-885-8610

**X-Rite Ltd.**

The Acumen Centre • First Avenue

Poynton, Cheshire • England

Tel: 9-011-44-0-1625-871100 • Fax: 9-011-44-0-1625-871444

**X-Rite Méditerranée**

Parc du moulin de Massy • 35, rue du Saule Trapu • 91300 Massy • France

Tel: 33-1-69.53.66.20 • FAX 33-1-69.53.00.52

**X-Rite Asia Pacific Limited - Japan Office**

Suite 506 AIOS Gotanda • 1-7-11 Higashi-Gotanda

Shinagawa-ku, Tokyo • 141-0022 Japan

Tel: 81-3-5447-1607 • Fax: 81-3-5447-1608