

X-Rite® 948/968

Color Measurement Instruments

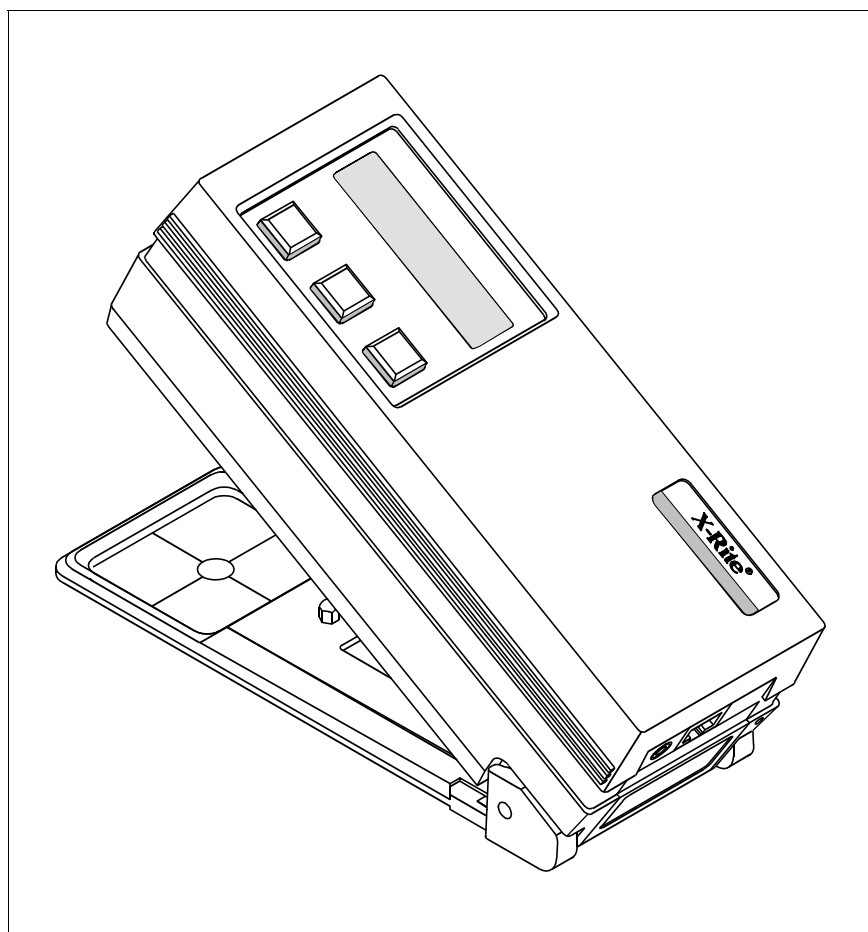

Operation Manual

CAUTION: Operational hazard exists if AC adaptor other than X-Rite SE30-61 (115V) or SE30-62 (230V) is used.

VORSICHT: Es besteht Betriebsgefahr bei der Verwendung von einem Adapter außer X-Rite SE30-61 (115 U) oder SE30-62 (230 U).

AVISO: No use otro adaptador C.A. que no sea la pieza X-Rite SE30-61 (115V) o SE30-62 (230V), por el riesgo de mal funcionamiento del equipo.

ATTENTION: Ne pas utiliser un autre adaptateur que la pièce X-Rite SE30-61 (115V) ou SE30-62 (230V).

AVVISO: Non usare un altro adattatore C.A. che non è del pezzo X-Rite SE30-61 (115V) o SE30-62 (230V), per il rischio di malfunzionamento dell'apparecchio.

NOTE: Shielded interface cables must be used in order to maintain compliance with the desired FCC and European emission requirements.

USE ONLY: AA NiCad batteries that are 600/700mAh rated, six required. Other types may burst causing personal injury.

AUFGEPASST: Verwenden Sie nur AA Nicad Akkus von 600/700mAhr (Milliampere/Stunde) Nennstrom (6 Stück erforderlich). Mit anderen Akkus läuft die Gefahr von Explosion und Verletzung.

ATENCION: Use solamente las pilas de AA NiCad (se requiere seis) con condiciones normales de funcionamiento 600/700mAhr (horas miliamperios). Es posible que los otros tipos puedan estallar y causar daños corporales.

ATTENTION: Utiliser seulement les batteries AA NiCad de 600/700mAhr (milliampère/heure) nominale (6 pièces nécessaire). Il y a danger d'explosion et des blessures avec des autres types.

ATTENZIONE: Usare solamente gli accumulatori al AA NiCad (si richiede sei) con le condizioni normali di funzionamento 600/700mAhr (ore milliamperi). E possibile che altri tipi possano scoppiare e causare danno personale.

WARNING: This instrument is not for use in explosive environment.

WARNUNG: Das Gerät soll in einer explosiven Umgebung NICHT verwendet werden.

ADVERTENCIA - NO use este aparato en los ambientes explosivos.

ATTENTION: Cet instrument NE DOIT PAS être utilisé dans un environnement explosif.

AVVERTIMENTO - NON usare questo apparecchio in ambienti esplosivi.

FCC

This equipment has been tested and found to comply with the limits for a Class A digital device, pursuant to Part 15 of the FCC Rules. These limits are designed to provide reasonable protection against harmful interference when the equipment is operated in a commercial environment. This equipment generates, uses, and can radiate radio frequency energy and, if not installed and used in accordance with the instruction manual, may cause harmful interference to radio communications. Operation of this equipment in a residential area is likely to cause harmful interference in which case the user will be required to correct the interference at his own expense.

Canada

This Class A digital apparatus meets all requirements of the Canadian Interference-Causing Equipment Regulations.

Cet appareil numérique de la classe A respecte toutes les exigences du Règlement sur le matériel brouilleur du Canada.

The Manufacturer: X-Rite, Incorporated
Der Hersteller: 3100 44th Street, S.W.
El fabricante: Grandville, Michigan 49418
Le fabricant:
Il fabbricante:

Declares that: Spectrophotometer
gibt bekannt: 948, 968
advierde que:
avertit que:
avverte che:

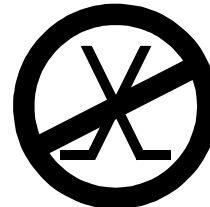

is not intended to be connected to a public telecommunications network.
an ein öffentliches Telekommunikations-Netzwerk nicht angeschlossen werden soll.
no debe ser conectado a redes de telecomunicaciones públicas.
ne doit pas être relié à un réseau de télécommunications publique.
non deve essere connesso a reti di telecomunicazioni pubblici.

DECLARATION OF CONFORMITY

complies to

EN45014:1989

Manufacturer's Name: X-Rite, Incorporated.
Manufacturer's Address: 3100 44th Street, S.W.
Grandville, Michigan 49418
U.S.A.

European Contact Name: X-Rite GmbH
European Contact Address: Stollwerckstraße 32
51149 Köln, Deutschland
(49) 2203-91450 FAX (49) 2203-914519

Model Name Spectrophotometer

Model No. 948 968

Year of Manufacture 1995

Directive(s) Conformance EMC 89/336/EEC LVD 73/23/EEC, 93/68/EEC

Test Standards Declared EN50081-1: 1992 EN55022 Class B Radiated, Class B Conducted
EN50082-1: 1992 IEC801-2,-3,-4 and EN60950

X-Rite, Incorporated and the undersigned, hereby declare under our sole responsibility that the product to which this declaration relates, conform to the above listed Directive(s) and Standard(s).

Grandville, Michigan

4-11-96



Location

Date

Mark P. Spliedt
Product Support Engineering Manager

NOTE: The device complies to the product specifications for the Low Voltage Directive when furnished with the 230VAC AC Adapter (X-Rite P/N SE30-62), and to UL Standards when furnished with the 115VAC AC Adapter (X-Rite P/N SE30-61).

Dear Customer:

Congratulations! We at X-Rite, Incorporated are proud to present you with an X-Rite Color Measurement Instrument. This instrument represents the very latest in microcontrollers, integrated circuits, fiber optics, and display technology. As a result, your X-Rite 948/968 is a rugged and reliable instrument whose performance and design exhibit the qualities of a finely engineered instrument, which is not surpassed.

To fully appreciate and protect your investment, we suggest that you take the necessary time to read and fully understand this manual. As always, X-Rite stands behind your unit with a one year limited warranty, and a dedicated service organization. If the need arises, please don't hesitate to call us.

Thank you for your trust and confidence.

*Ted Thompson
Chairman and CEO*

Table of Contents

Opening Letter.....	i
Proprietary Notice.....	iii
General Description.....	iv
User Interface.....	vi
What To Do First!.....	vii
1. Getting Started.....	1
1.1 Packaging Check list.....	1
1.2 Shoe Lock.....	3
1.3 Battery Charging.....	4
1.4 Applying Power.....	4
2. Positioning Techniques.....	5
3. Operation.....	7
3.1 Keyswitch Descriptions.....	7
3.2 Function Selection.....	8
3.3 Illuminant/Observer Selection.....	10
3.4 Absolute Measurement.....	12
3.5 Difference Measurement.....	13
3.5.1 Entry of Reference Values.....	14
3.5.2 Taking A Difference Measurement.....	18
3.6 CMC Difference Operation.....	19
3.7 Measurement Averaging Procedure.....	21
3.8 Store Data Operation.....	23
3.9 Display Messages.....	26
4. Calibration.....	28
4.1 Positioning the Instrument on the X-Rite Calibration Standard.....	29
4.2 Calibrating to a White Standard.....	32
5. Setting System Parameters.....	35
5.1 Averaging.....	35
5.2 Operation Parameters.....	37
5.3 RS232 I/O Parameters.....	39
5.4 Format Output Parameters.....	41
6. Printing Data.....	43
7. Changing Apertures.....	47
8. Maintenance.....	49
8.1 Troubleshooting.....	49
8.2 Optics Cleaning.....	50
8.3 Battery Replacement.....	51
8.4 Target Window Replacement.....	52
8.5 Lamp Replacement.....	53
Appendix	
A1 - Specifications.....	54
A2 - Optional Accessories.....	55
A3 - Factory Presets.....	56
A4 - Spectrophotometer Stand.....	57
A5 - Color Check.....	58

PROPRIETARY NOTICE: The information contained in this manual is derived from patent and proprietary data of X-Rite, Incorporated. This manual has been prepared expressly for the purpose of assisting in the use and general maintenance of this instrument.

Publication of this information does not imply any rights to reproduce or use this manual for purposes other than installing, operating, or maintaining this instrument. No part of this manual may be reproduced, transcribed, transmitted, stored in a retrieval system, or translated into any language or computer language, in any form or by any means, electronic, magnetic, mechanical, optical, manual, or otherwise, without the prior written permission of an officer of X-Rite, Incorporated.

These provisions are intended to state all of the rights and responsibilities between X-Rite, Incorporated and the customer. They supersede all warranties, expressed or implied, and whether of merchantability, fitness or otherwise. The remedies contained in this manual are exclusive. Customer and X-Rite, Incorporated waive all other remedies, including but not limited to consequential damages.

This instrument is covered by one or more of the following U.S. and foreign patents:
U.S. patent #4,080,075, #4,591,978, and other patents pending.

Copyright © 1990 by X-Rite, Incorporated
"ALL RIGHTS RESERVED"

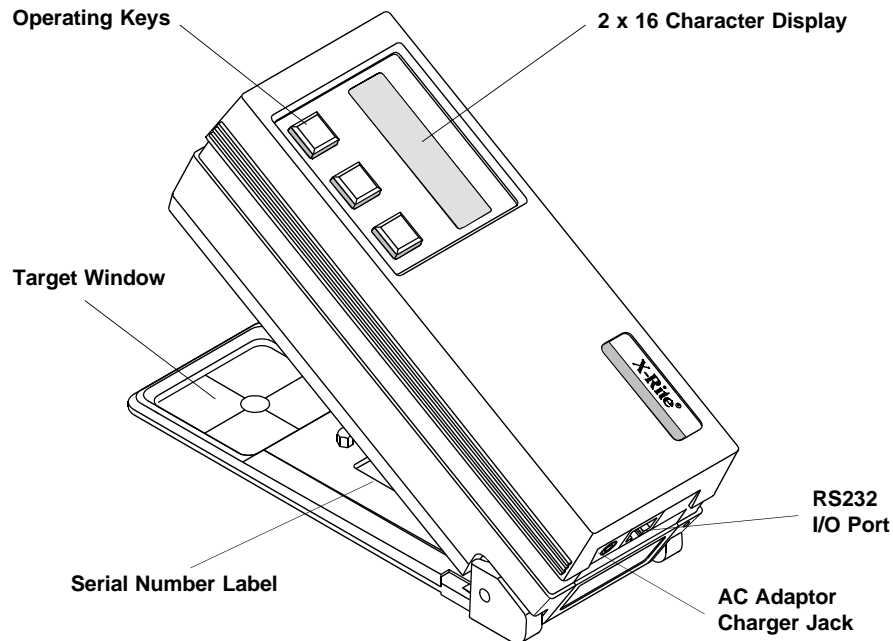

LIMITED WARRANTY: X-Rite, Incorporated warrants each unit manufactured to be free of defects in material and workmanship (excluding Ni-Cad batteries) for a period of twelve months. THERE ARE NO WARRANTIES OF MERCHANTABILITY OR FITNESS. THIS WARRANTY OBLIGATION IS LIMITED TO SERVICING THE UNIT RETURNED TO X-RITE, INCORPORATED or AN AUTHORIZED SERVICE DEALER FOR THAT PURPOSE. The unit shall be returned with transportation charges prepaid. If the fault has been caused by misuse or abnormal conditions of operations, repairs will be billed at a nominal cost. In this case, an estimate will be submitted before work is started, if requested. Always include serial number in any correspondence concerning the unit. The serial number is located on the bottom housing.

X-Rite, Incorporated offers a repair program for instruments out of warranty. For more information, contact X-Rite Instrument Services Department.

This agreement shall be interpreted in accordance with the laws of the State of Michigan and jurisdiction and venue shall lie with the courts of Michigan as selected by X-Rite, Incorporated.

General Description

The X-Rite 948 is a reflection *spectrocolorimeter*. The 948 measures spectral reflectance from 400nm to 700nm in 20nm intervals. It has a 0° illumination angle, a 45° viewing angle, and features a dual-beam, single light pulse compensation method to insure accuracy.

The 948 calculates and displays colorimetric data. In addition, the 948 can output (to a printer or computer) colorimetric data. An optional software package, *ColorStart*®, can collect, sort, view, and analyze L*a*b* data using an IBM (or 100% compatible) computer.

The X-Rite 968 is a reflection *spectrophotometer*. The 968 measures spectral reflectance from 400nm to 700 nm in 20nm intervals. It has a 0° illumination angle, a 45° viewing angle, and features a dual-beam, single light pulse compensation method to insure accuracy.

The 968 calculates colorimetric and spectrophotometric data. The 968 displays colorimetric data, and can output (to a printer or computer) colorimetric and spectral data. An optional software package, *SpectroStart*®, can collect, sort, view, and analyze L*a*b* and spectral data using an IBM (or 100% compatible) computer.

The 948 and 968 measure spectral reflectance, absolute color or color difference, and absolute index or index difference for Whiteness and Yellowness.

- XYZ or RGB & Δ XYZ or Δ RGB (CIE 1931 or RGB = X%Y%Z%)
-  > Z% is one method used to measure paper brightness. Refer to Section 5.2 to activate RGB (X%Y%Z%).
- Yxy & Δ Yxy (CIE 1931)
- L*a*b* or Lab & Δ L*a*b* or Lab (CIE 1976 or HUNTER)
- L*u*v* & Δ L*u*v* (CIE 1976)
- L*C*h° & Δ L*C*H* (CIE 1976, ab, CMC, or uv)
- Whiteness & Tint & Δ Whiteness & Tint (CIE & ASTM E313)
- Yellowness & Δ Yellowness (ASTM E313 & ASTM D1925)

The 948 and 968 have eight different CIE Illuminants for calculations under varying lighting conditions. In addition, you can select the CIE 1931 2° Observer or the CIE 1964 10° Observer.

- Illuminant C
- Illuminant D₆₅
- Illuminant D₅₀
- Illuminant A
- Illuminant F2 (Cool White Fluorescent)
- Illuminant F7 (Narrow-band White Fluorescent)
- Illuminant F11 (TL84 / Wide-band Fluorescent)
- Illuminant F12 (Ultralume 3000)

Twenty four different *reference values* (Ref 01 - Ref 24) can be entered into the 948 and 968 manually (numerically) or by measuring a reference sample. The exceptions are that the reference values for Δ Whiteness and Δ Yellowness can only be entered by measurement. During reference entry all color spaces are automatically updated when a change has been made in one of them.

The 948 and 968 can function as color difference meters. By entering in your reference (by measurement or numerically), the units will indicate the amount of difference between the reference and the measured sample.

The *store data* feature allows the units to store up to five hundred measurements for transferring to a printer or computer (via RS232) at a later time.

The *CMC difference* feature provides a single numeric value (ΔE_{CMC}) which describes the color difference between a sample and a standard.

The *averaging feature* allows the units to make several measurements from the same and/or different locations on a sample or reference. This will allow for a better overall average of a color.

The units are powered by six AA rechargeable batteries, or by the AC adaptor/charger provided. Additionally, the units retain calibration and reference values when turned off, or if the Ni-Cad batteries are discharged.

User Interface

This section will familiarize you with the typographical conventions, display functions, and general terms used in this manual.

- In the text portion of this manual the 968 keys are shown with brackets on both sides and in boldface. Ex., **[FUNCTION]**, **[ILLUM]**, and **[DIF]**.
- When a key is to be momentarily pressed, the statement "press" will be used. Ex., Press **[FUNCTION]**.
- When a key is to be held depressed until another action occurs, the statement "hold down" will be used. Ex., Hold down **[ILLUM]** until "**SELECT ILLUMINANT**" is displayed.
- Information that will appear in the display window will be shown with quotation marks on each side and in boldface. Ex., "**SELECT ILLUMINANT**"

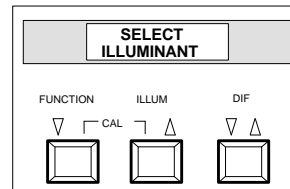

- The symbols ▼ and ▲ represent the blue and red arrows on the 968. In calibration and reference value entry the arrows indicate which direction a value can be changed. Holding **[DIF]** depressed and pressing **[▼]** decreases the value and **[▲]** increases the value.

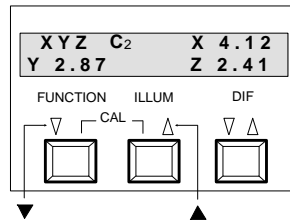

- The term "cursor" represents a black rectangle that will blink next to or over a value or function in the display. In most cases it means that value is active and can be altered via the **[▼]** and **[▲]** keys.

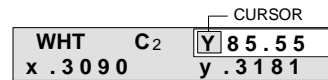

- A "hand" indicates important notes and possible operations that need to be performed before the normal operation.



- When a procedure is continued on the next page an arrow will appear in the bottom right hand corner of the page.



- Illuminant/observer combinations are expressed by special notations (Ex., D_{65}^2 indicates illuminant D, 6500°k, and 2° observer).
-

What To Do First!



See how to unlock the shoe and charge the batteries...read *Section 1 - Getting Started*.



See how the positioning of the instrument during measurement affects the reading...read *Section 2 - Positioning Techniques*.



Calibrate your instrument...read *Section 4 - Calibration*.



Setup your instrument. You can set the operating parameters, RS232 parameters, and format output parameters of your unit. Remember, you can lock out of the display any function you do not want to use...read *Section 5 - Setting System Parameters*.



Learn the basic functions...read *Section 3 - Operation*.

1. Getting Started

1.1 Packaging Check List

After removing the instrument from the shipping carton, inspect for possible damage. If any damage is noted, contact the transportation company immediately. Do nothing more until the carrier's agent has inspected the damage.

If damage is not evident, check and make sure that all items are included (Refer to the parts list below, and following page for the packaging illustration).

Your unit was packaged in a specially designed carton to assure against damage. If reshipment is necessary, the instrument should be packaged in the original carton. If the original carton is not available, a new one can be obtained from X-Rite Inc. Refer to the packaging drawing on the following page (items 1, and 2).

PACKAGING PARTS LIST

25	1	1	1	1	SD01-40	CERTIFICATE OF CALIBRATION
24	1	1	1	1	SD43-968-62	REFLECTANCE LABEL
23						
22	1	1	-	-	SD43-22	UL LISTING LABEL
21						
20	1	1	1	1	SD65-13	PLASTIC BAG
19	-	-	1	1	SE30-62	AC/DC ADAPTOR 230 VAC 50/60 Hz
	1	1	-	-	SE30-61	AC/DC ADAPTOR 115 VAC 50/60 Hz
18	1	-	1	-	SD43-27	LABEL
17	2	1	2	1	SD65-03	PLASTIC BAG
16	1	-	1	-	968-61-04	4mm APERTURE ATTACHMENT
15	-	-	-	-	968-121-20	20mm TARGET WINDOW
	-	-	-	-	968-121-08	8mm TARGET WINDOW
	1	-	1	-	968-121-04	4mm TARGET WINDOW
14	1	1	1	1	SD01-11	CHARGING NOTE
13	1	1	1	1	SD01-10	IMPORTANT NOTICE "SERVICE"
12	1	1	1	1	SD01-16	POSITION NOTICE
11	1	1	1	1	SD01-04	WARRANTY REGISTRATION
10	1	1	1	1	968-500	OPERATION MANUAL
9	1	1	1	1	SD68-10	ENVELOPE
8						
7	1	1	1	1	968-601	REFERENCE GUIDE
6	1	1	1	1	968-62	CALIBRATION REFLECTION STANDARD
5	-	1	-	1	968L-00-01	SPECTROPHOTOMETER ASSY-20mm
	1	-	1	-	968-00-01	SPECTROPHOTOMETER ASSY- 8mm
4	1	1	1	1	SD65-10	PLASTIC BAG
3	1	1	1	1	418-67-01	CARRYING CASE
2	2	2	2	2	SD200-880-06	CARTON INSERT
1	1	1	1	1	SD200-880-01	CARTON
ITEM	968 QTY	968L QTY	968X QTY	968LX QTY	PART NUMBER	DESCRIPTION
PARTS LIST						

PACKAGING

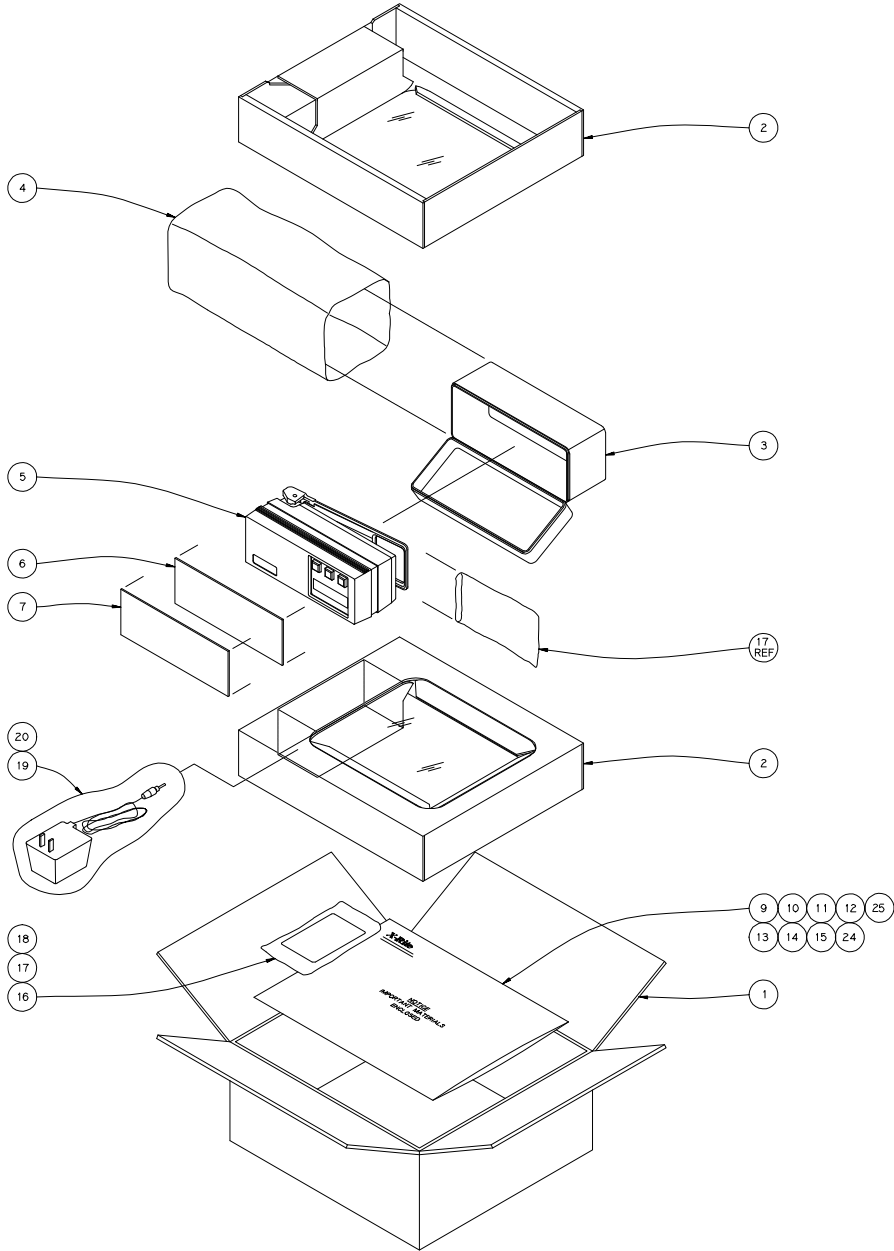

1.2

Shoe Lock

The shoe can be locked next to the housing for ease of storage.

Unlocking Shoe

1. Hold shoe [1] against unit.
2. Slide black lock button [2] on bottom of unit towards the back until it stops, then slowly release shoe [1].

Locking Shoe

1. Hold shoe [1] against unit.
2. Slide black lock button [2] towards the front until it stops, then release shoe [1].

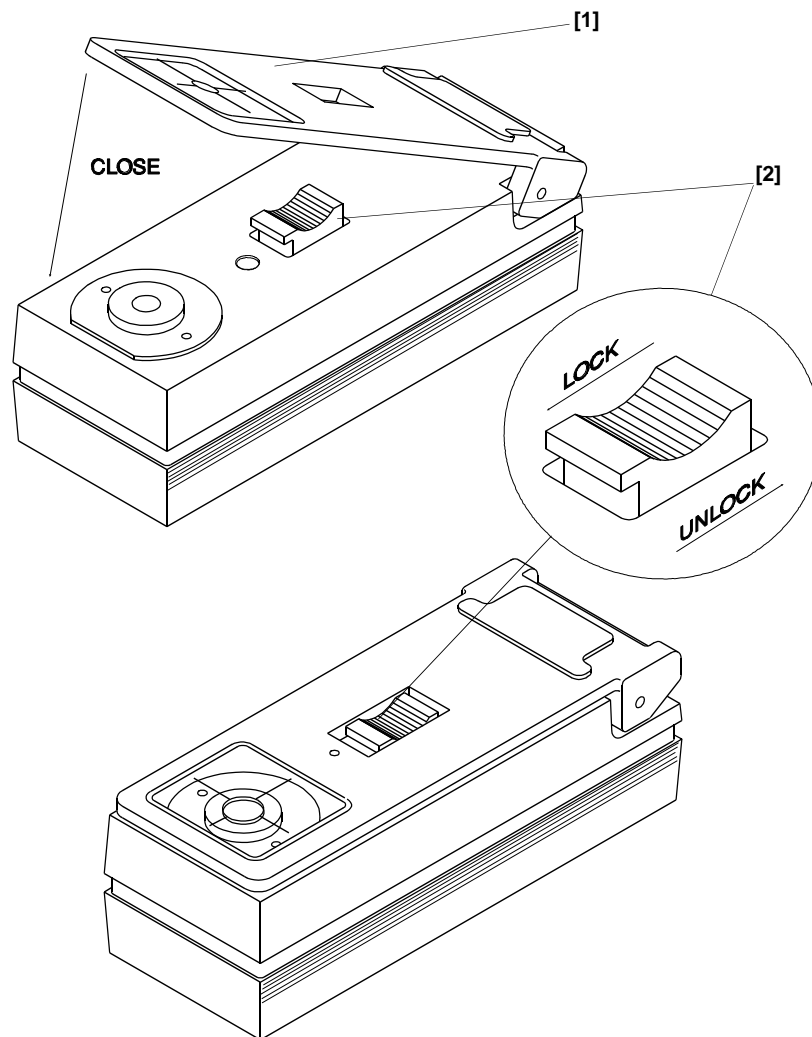

1.3

Battery Charging



- > THE UNIT SHOULD BE CHARGED BEFORE USE. The unit can be operated while the batteries are being charged. Before using make sure the voltage indicated on the AC adaptor complies with the AC line voltage in your area. If not contact your X-Rite dealer.
- > The unit should be fully charged in 14 hours. Note: If your unit has not been used for several weeks recharge for approximately 24 hours.
- > Charging the batteries for less than 14 hours will reduce the operating time of the unit.
- > The best method to obtain the maximum battery life is to:
 - Always run the unit down to the point where the "BATTERIES LOW" message is displayed. Then charge the unit before the next message "CHARGE BATTERIES" is displayed.
 - Leaving the unit plugged into the AC wall outlet for extended periods of time (over 48 hours) may shorten the battery life.
 - If you are going to store the unit for an extended period of time (over 6 months) you should remove the Ni-Cad batteries from the unit.

1. Plug the small connector end of the adaptor into back of unit.
2. Plug the adaptor into AC wall outlet.

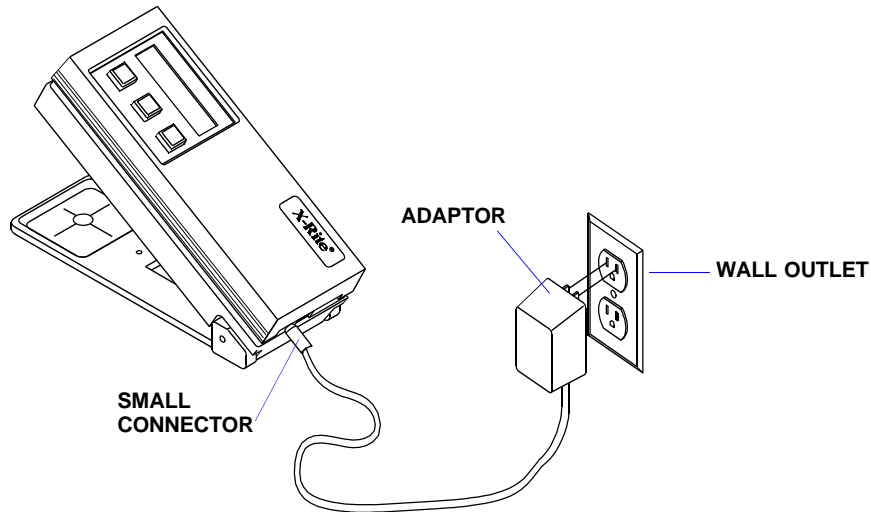

- > This unit retains calibration, reference values, and all other data when the unit turns off after 45 seconds of non-use (in battery operation), or if the Ni-Cad batteries are discharged.

1.4

Applying Power

During battery operation power is applied automatically when a measurement is taken or if a key is pressed. It automatically shuts off (within 45 seconds) if no keys are pressed or no further measurements are taken. The unit will not automatically shut off if the AC adaptor is connected.

2. Positioning Techniques

The variety of items that the 948 and 968 can measure is almost endless. However, in order to obtain accurate and repeatable measurements, the bottom of the shoe must be:

- *Parallel* with the surface to be measured if the surface is *flat*.
- *Tangent* to the surface to be measured if the surface is *curved*.

The reason for this is that any movement during measurement can cause the reading to vary. To obtain the most accurate and repeatable measurements, there are a few guide rules you can follow.

If the item to be measured is smaller than the shoe, you may want to make a platform (the same height of the item) for the instrument to sit on. If the item to measure is curved, you may want to make a jig for the item to rest in.

Shown below and on the next page are some examples of methods used to accomplish this. Example 1 shows a platform for measuring a paint chip. Example 2 shows a jig being used to measure a cup. Example 3 shows a jig being used for measuring a small knob.

Note: A mounting fixture (jig) is available from X-Rite (P/N 968-80). The jig can measure objects that are a maximum of 4" inches in width, or 2" to the center of the object. Refer to Appendix A-4 for further information about this mounting fixture.

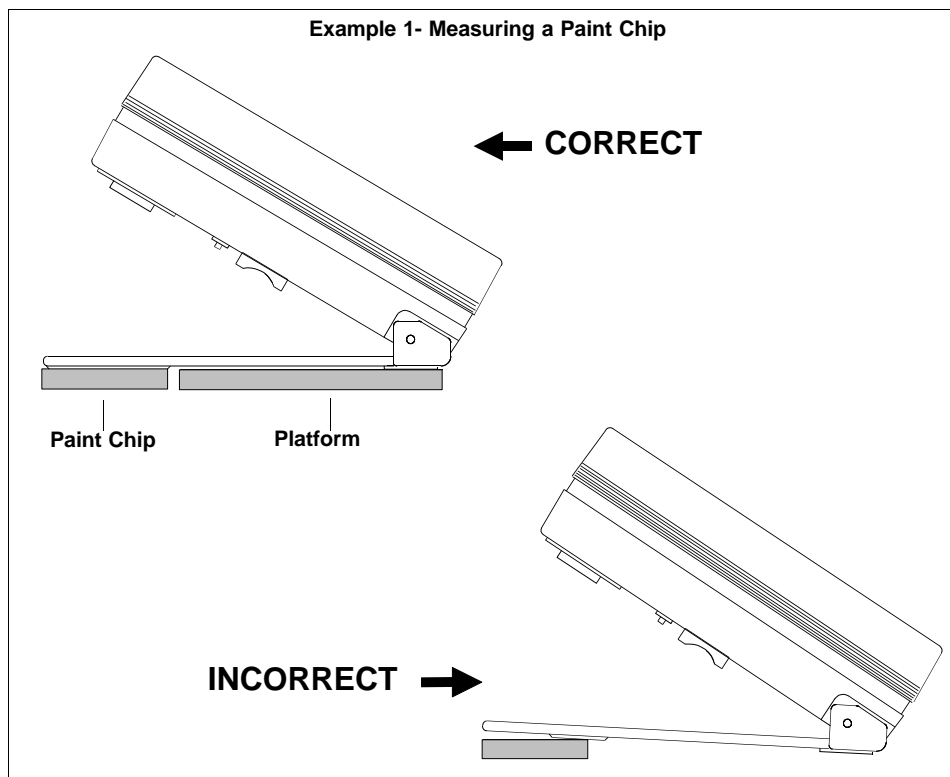

Example 2 - Measuring a Coffee Cup

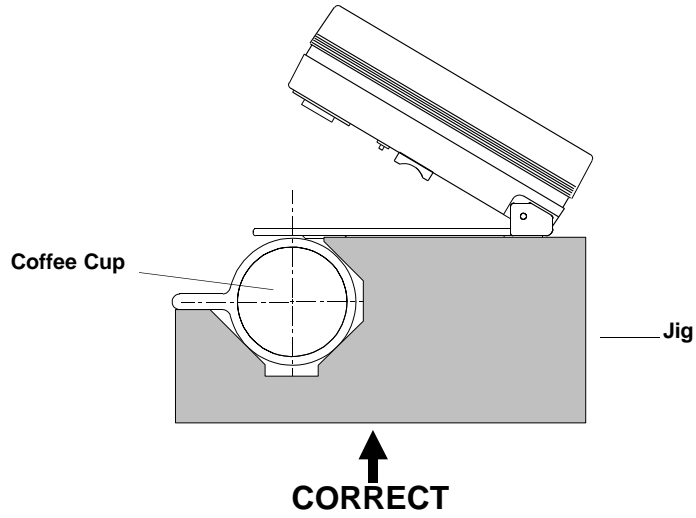

Example 3 - Measuring a Small

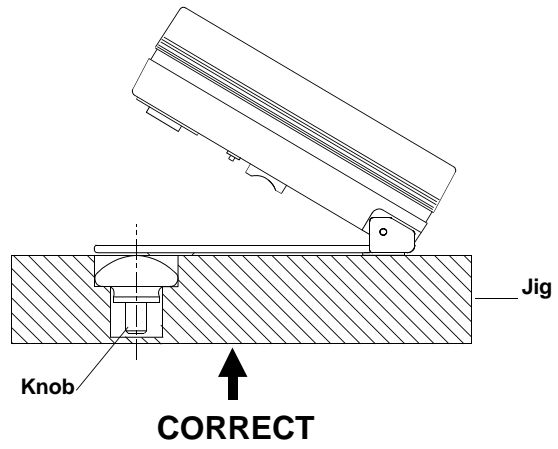

3. Operation

3.1 Key Descriptions

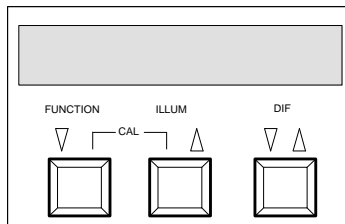

[FUNCTION]/[▼]

See Section

- Selects the function that will be used for measurement. Each momentary depression will cause the display to page through XYZ, Yxy, L*a*b*, L*u*v*, L*C*h°, Whiteness, & Yellowness. 3.2
- Decreases numeric values when used with the [DIF] key during entry of reference or calibration values. 4.0
- Selects Calibration when pressed with [ILLUM] key. 4.0
- Selects various steps when in system setup procedures. 5.0

[ILLUM]/[▲]

- When held depressed activates illuminant/observer selection, thereafter, momentary depressions select the illuminant to be used. The available illuminants are: 3.3

C D₆₅ D₅₀ A
F2 F7 F11 F12

Note: the [DIF] key selects the Observer (CIE 1931 2° or CIE 1964 10°) to be used.

- Increases numeric values when used with [DIF] key during entry of reference or calibration values. 4.0
- Displays the reference number when pressed momentarily. 3.5
- Selects Calibrate when pressed with the [FUNCTION] key. 4.0

[DIF]/[▼▲]

- When at function level, toggles Delta (Δ) On and Off with each depression. Delta being the difference mode. 3.5
- Decreases reference or calibration values when used with the [FUNCTION] key. 4.0
- Increases numeric values when used with the [ILLUM] key. 4.0

3.2 Function Selection

Each momentary depression of [FUNCTION] will sequentially page through the available functions: CIE XYZ (or RGB), Yxy, L*a*b* (or Lab Hunter), L*u*v*, ^a_bL*C*h° (or ^u_vL*C*h°), Whiteness, & Yellowness.

If Δ is active the following is displayed

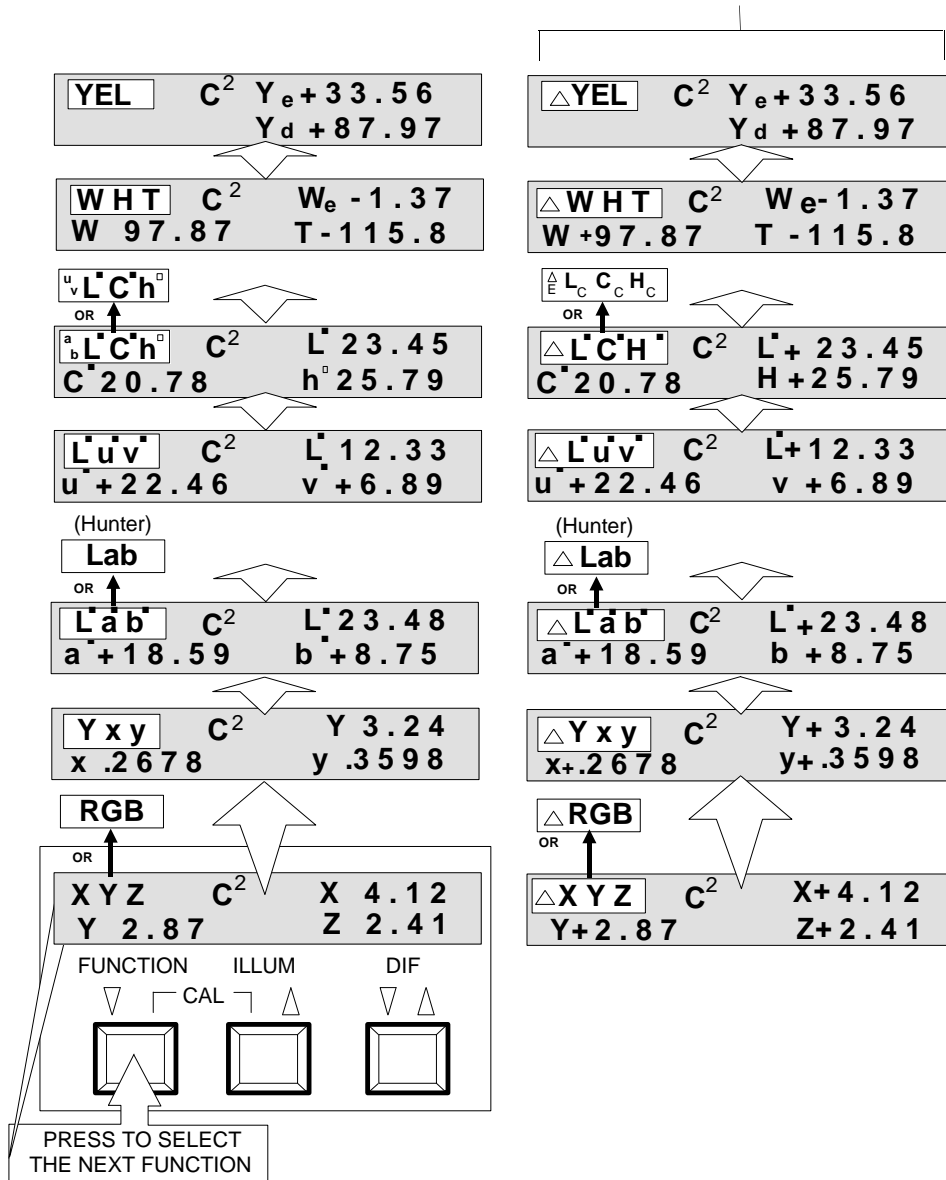

- > The illuminant/observer will not be displayed in the difference mode during operation of that function. It is only displayed during function selection.
- > ΔE will be displayed in place of $\Delta L^*a^*b^*$, $\Delta L^*u^*v^*$, and $\Delta L^*C^*H^*$ during difference operation.

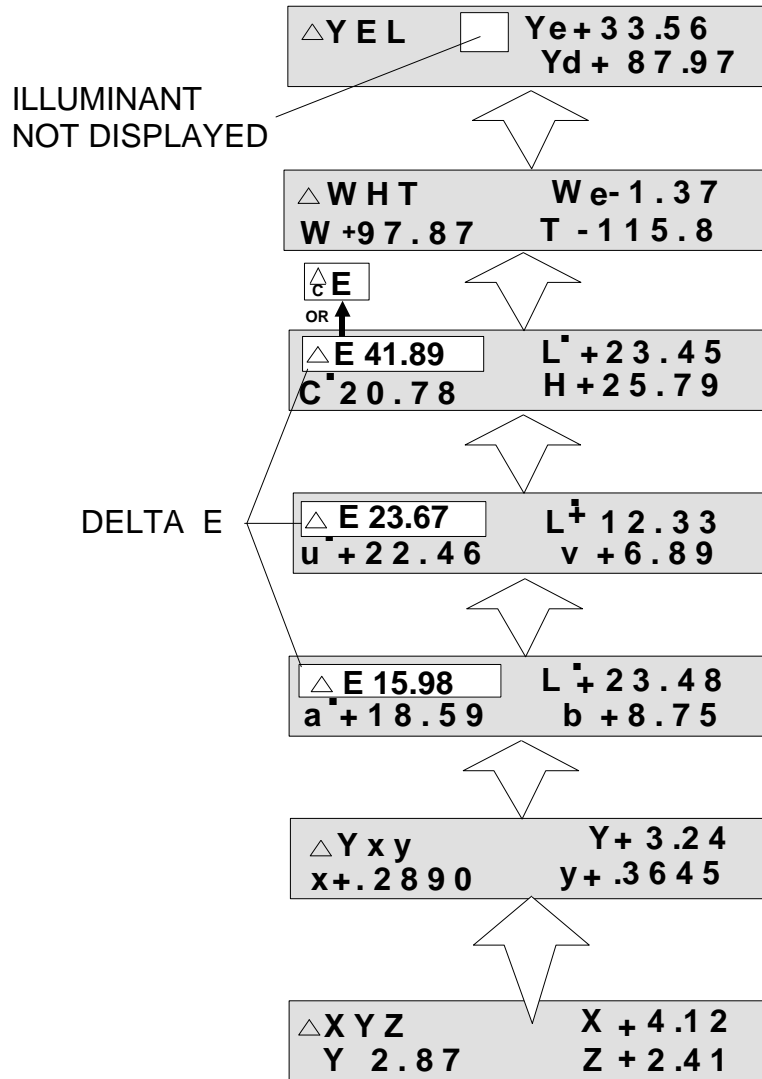

3.3 Illuminant/Observer Selection

There are eight different illuminants and two observers to choose from.

- 1) To enable illuminant selection: Hold down [ILLUM] until "SELECT ILLUMINANT" is displayed.

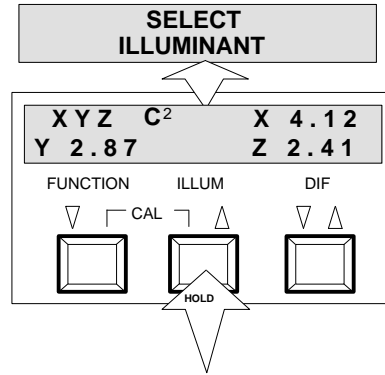

- 2) The active illuminant & observer are displayed.

Press [ILLUM] to select a different illuminant.

Note: Illuminant F2 represents a cool white fluorescent lamp.

Illuminant F7 represents a broad-band daylight fluorescent lamp.

Illuminant F11 represents a narrow-band white fluorescent lamp (or illuminant TL84).

Illuminant F12 represents Ultralume 3000.

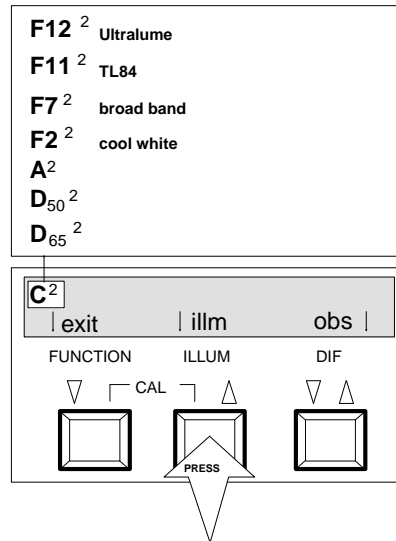

Press [DIF] to select a different observer.

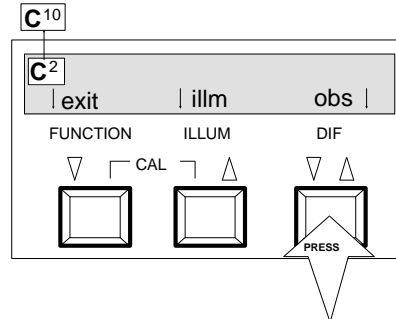

Continued

3) To exit press **[FUNCTION]**.

When "Function Key" is pressed, the instrument will automatically convert the stored spectral references (if any) to tristimulus for the different illum/obs selected. The unit will also ask if you would like the references to be cleared. If you do not want the references cleared (or you do not have any entered), disregard the procedure below.

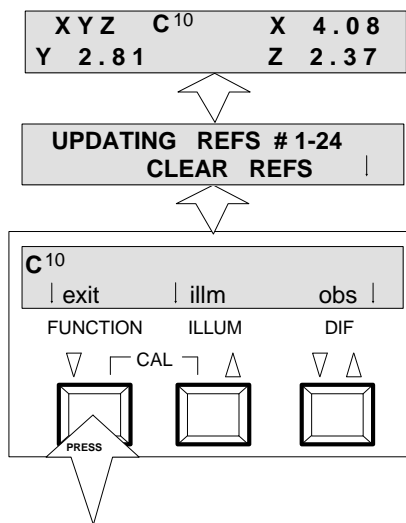

Clearing References

The "Clear Reference" function is useful if the Illum/Obs is being changed often, and many references exist in the instrument that are not being used. This will enable the operator to speed up the time it takes the instrument to recalculate to a different illum/obs.

Press **[DIF]** to enter clear reference function. After the "Dif Key" is pressed "**CLEAR REFERENCES** ↓**NO YES**↓" is displayed. Press **[DIF]** to clear or **[FUNCTION]** not to clear.



- > You must press the "Dif" key while the unit is recalculating the references to activate this function.
- > If the clearing procedure is carried out, all references (measured & numerically entered) will be removed.
- > Refer to Section 3.5 for a more detailed explanation on measured and numerically entered references.

3.4 Absolute Measurements

The 948 and 968 can perform absolute measurement in XYZ (RGB), Yxy, L*a*b*, L*u*v*, L*C*h°, Whiteness, & Yellowness.

-  **Helpful Hint:** If you are going to measure something like a textile, you will receive better results if you use the averaging function (see Section 3.6). Also, while measuring a textile, take several measurements in a circular format.
- > If the Δ is displayed, press **[DIF]** to activate absolute mode.
- > If the desired illuminant/observer is not displayed, refer to Section 3.3.

- 1) Press **[FUNCTION]** to select desired measurement space.

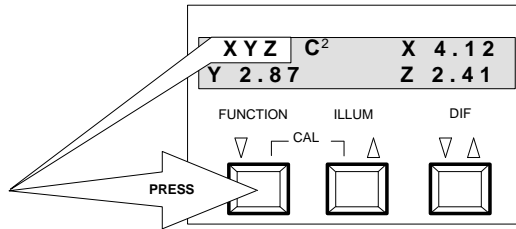

- 2) Center the target window over the area to be measured.

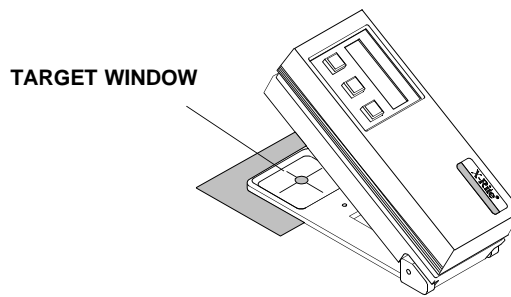

- 3) Lower unit to target window and hold compressed. **"READING XYZ C²"** (i.e., the selected function & the illum/obs) will momentarily be displayed, and then the data. Release unit after data is displayed.

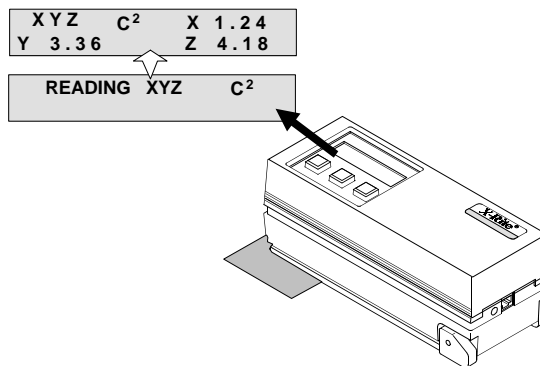

- 4) The display will show the absolute values for XYZ.

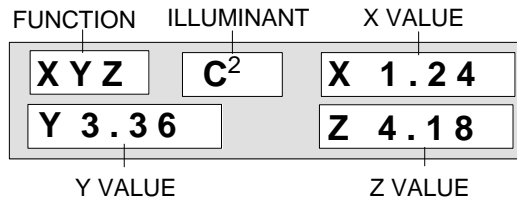

3.5 Difference Measurement

The 948 and 968 can measure the difference between a sample color and a reference. In order to measure these differences the reference must first be entered into memory. There are 24 different locations to store references.

The reference can be entered numerically using the key pad, or by measuring the reference color.

 > The Δ Whiteness and Δ Yellowness reference color can only be entered by measurement.

Reference (Measurement)

Measured references are stored spectrally and the tristimulus values are recalculated each time a different illum/obs is selected. As long as references are measured, the instrument can automatically convert the spectral data to allow for viewing of difference measurements under various illum/obs sets.

Reference (Numeric)

Numerically entered references are saved with the selected illum/obs. A total of 7 sets of numerically entered tristimulus values (with different illum/obs) can be stored in each reference location.

If a different illum/obs is selected and no numerically entered reference supports that illum/obs, the instrument will turn "OFF" that reference location.

The instrument can not recalculate to a different illum/obs if it was not previously entered during numeric reference entry.

Operation Mode

The instrument can be set to operate in an automatic mode, where it will automatically select the closest reference; or in manual mode, where you have to manually select the reference locations you want to use. Refer to Section 5.2, Setting Operation Parameters for information on selecting manual or automatic reference operation.

In automatic mode, the instrument will select the reference that is closest to the measured color. If by some chance it is not the correct reference, simply press the [ILLUM] key twice and the unit will select the next closest reference.

In manual mode, you must manually select the reference. Once you have selected a reference, that reference will be used until you select a different reference.

To activate the Difference mode, press [DIF] and the Δ sign will appear in the display. The Δ Functions will have a "+" sign in front of them for positive values instead of being implied as in the absolute function.

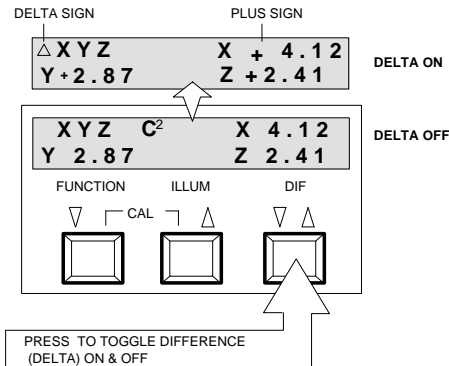

 > $\Delta L^*a^*b^*$, $\Delta L^*u^*v^*$, & $\Delta L^*C^*H^*$ show ΔE in function location.



- > When entering references with any illuminant other than C², Yellowness and Whiteness (per ASTM E313) are not calculable.
- > Once a reference has been set, changing between CIE Lab or Hunter Lab; Lch (ab) or Lch (uv); and XYZ or X%Y%Z%, the references will not be automatically adjusted.

Note: You can set all reference locations to OFF by:

- Activating difference mode.
- Hold down [DIF] until reference entry is activated, then simultaneously press [ILLUM] and [FUNCTION].

Ref 1 defaults to ON if all references are turned OFF.

Refer to Steps 2 and 3 below.

3.5.1 Entry of Reference Values By Measurement

- 1) Select desired Illum/Obs (see Sec. 3.3).
- 2) Press [FUNCTION] to select desired measurement space.

- > If Δ is not displayed, press [DIF] to activate Difference mode.

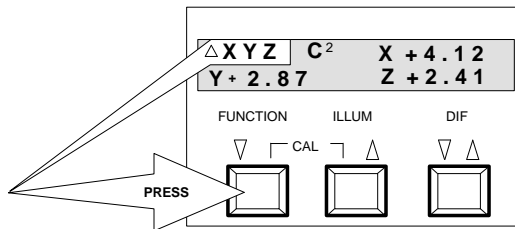

- 3) Hold down [DIF] until "SET REF VALUES - ENTER or MEASURE" is displayed. First displayed are the previous entered reference values for the last selected reference location.

The reference location is momentarily displayed.

Then "EXIT" is displayed.

- > You can set all reference locations to OFF by: holding down [DIF] then simultaneously pressing [ILLUM] and [FUNCTION]. Note, Ref 1 defaults to ON.

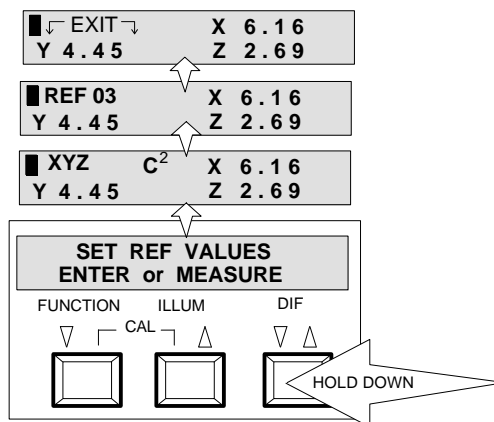

Continued

4) Select the reference location.

If the cursor is not blinking next to the reference location, press **[DIF]** until it does.

Hold down **[DIF]** and press **[▼]** to decrement thru the reference locations or press **[▲]** to increment.

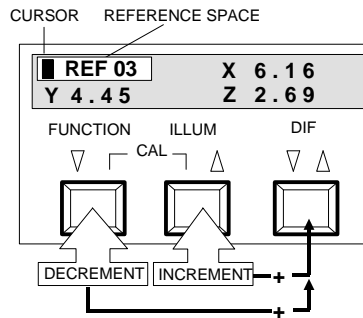

5) Measure the reference color.

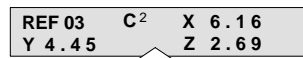

Reference Color

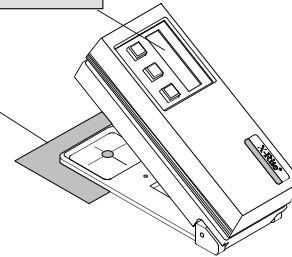

6) Press **[FUNCTION]** and **[ILLUM]** at the same time to exit to the main menu.

"REFERENCES UPDATED" is momentarily displayed and the procedure is finalized.



> If no measurement or entry is made the unit will display "REFERENCES - NOT CHANGED."

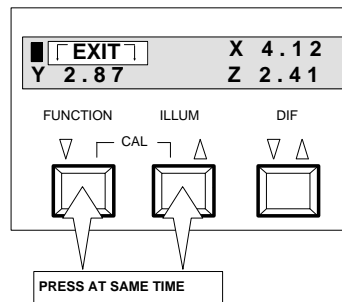

Entry of Reference Values... By Numeric Entry

 > Whiteness & Yellowness reference values can not be entered via the keyboard.

- 1) Select desired Illum/Obs (see Sec. 3.3).
- 2) Press **[FUNCTION]** to select desired measurement space.

 > If Δ is not displayed, momentarily press **[DIF]** to activate Difference mode.

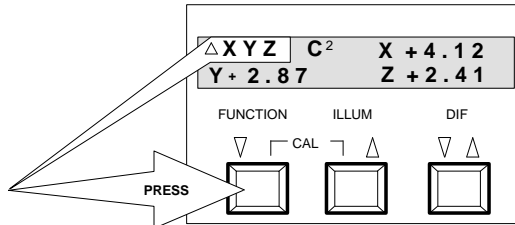

- 3) Hold down **[DIF]** until "SET REF VALUES - ENTER or MEASURE" is displayed.

The unit will first display the previous entered reference values for the last selected reference location.

The reference location is momentarily displayed.

Then "EXIT" is displayed.

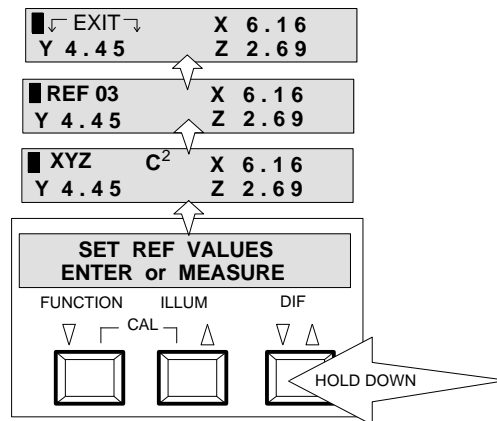

- 4) Select the reference location. If the cursor is not blinking next to the reference location, press **[DIF]** until it does.

Hold down **[DIF]** and press **[▼]** to decrement thru the reference locations or press **[▲]** to increment.

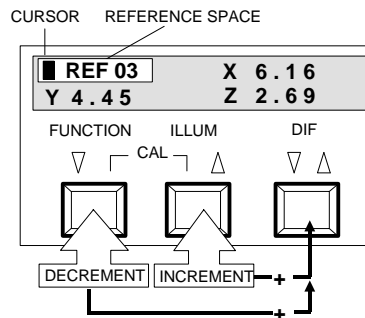

 Continued

5) The cursor will blink over the active value that can be edited. Enter the numbers for each value.

- The [DIF] key advances the cursor to the next value to be edited.
- The [DIF] key is used in conjunction with [▼] to decrease and [▲] to increase the value. **Note:** Hold [DIF] depressed then press either [▼] or [▲] to change value.

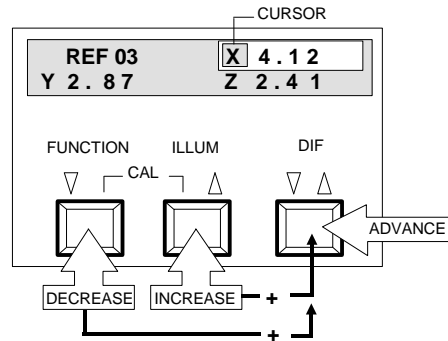

6) Press [FUNCTION] and [ILLUM] at the same time to exit to the main menu.

"REFERENCES UPDATED" is momentarily displayed and the procedure is finalized.

-  > If no measurement or entry is made the unit will display "REFERENCES - NOT CHANGED."

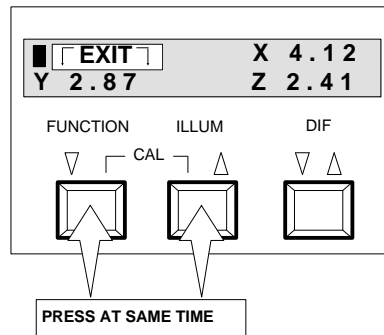

3.5.2 Taking A Difference Measurement

-  > If the Δ is not displayed, press [DIF] to activate difference mode.
- > The reference color must first be entered into memory, refer to Section 3.5.1.
- > If reference selection is not set to auto, select the correct reference location before following the procedure below (refer to Section 3.5.1).
- > If the desired illuminant/observer is not displayed, refer to Sec. 3.3.

1) Press [FUNCTION] to select desired measurement space.

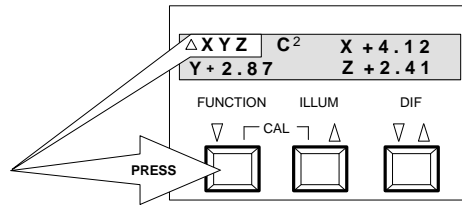

2) Center target window over area to be compared.

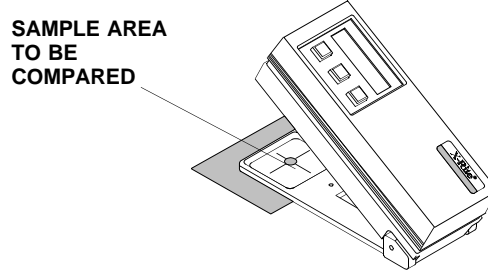

3) Lower unit to target window and hold compressed. "READING XYZ C²" (i.e., the selected function and illum/obs) will momentarily be displayed, and then the reference location and data.

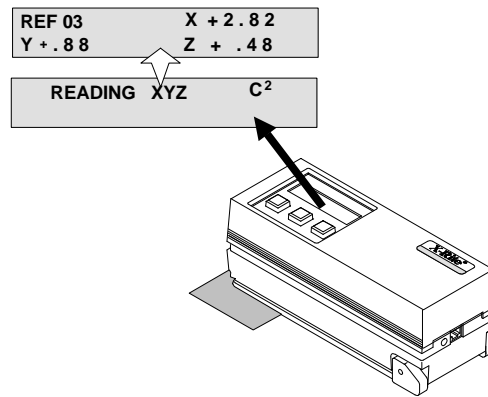

Release unit after data is displayed.

4) The display will show the difference between the reference color and the area measured.

-  > If L*a*b*, L*u*v*, or L*C*H* are selected, ΔE value will be displayed in place of the Function & Illuminant.
- > If you want to display the selected reference location, press [ILLUM].

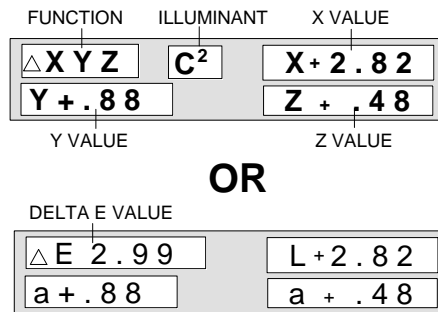

3.6 CMC Difference Operation

CMC is an ellipsoidal tolerancing method which attempts to correlate small measured color differences with visual assessment.

CMC provides a single numeric value (ΔE_{CMC}) which describes the color difference between a sample and a standard. This allows the use of a single tolerance value for comparing the acceptability of a color match.

ΔE_{CMC} is derived from the following formula:

$$\Delta E_c = [L_c^2 + C_c^2 + H_c^2]^{1/2}$$

$$L_c = \frac{\Delta L}{\phi L} \quad C_c = \frac{\Delta C}{c S_L} \quad H_c = \frac{\Delta H}{S_H}$$

The CMC reference menu consists of the three factors that can be set: Lightness factor (l), Chromaticity factor (c), and Commercial factor.

- The lightness factor is normally set to 2.00 (default) but other values may be required when surface characteristics differ dramatically.
- The chromaticity factor normally does not require any adjustment from the default setting of 1.00.
- The commercial factor is the tolerance limit that each sample is not to exceed. (e.g., if cf= 1.00 then any sample which has a ΔE_{CMC} value greater than 1.00 would be commercially unacceptable.)

To Setup CMC Difference:



- > CMC Option is only available on L*C*H* difference function.
- > CMC option must first be selected in Operation Parameters (Sec. 5.2).

1) Follow Step 1 through 5 in Section 3.5.1 for entering a reference manually or by measurement.

2) Press **[DIF]** until the CMC menu is displayed. The cursor will blink over the active value that can be edited. Enter the number for each value.

- The **[DIF]** key advances the cursor to the next value to be edited.
- The **[DIF]** key is used in conjunction with the **[▼]** to decrease and **[▲]** to increase the value. **NOTE:** Hold **[DIF]** depressed then press either **[▼]** or **[▲]** to change values.

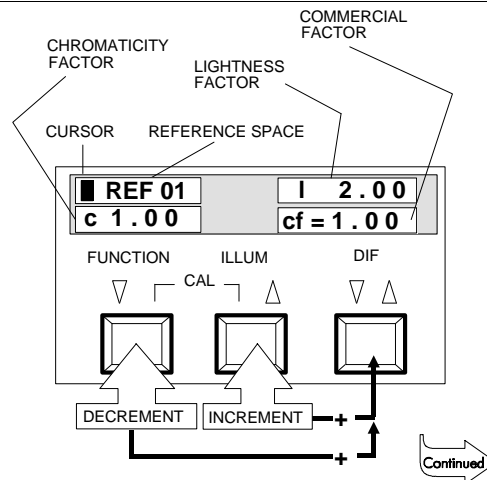

- 3) Press **[FUNCTION]** and **[ILLUM]** at the same time to exit to the main menu. "REFERENCES UPDATED" is momentarily displayed and the procedure is finalized.

 > If no measurement or entry is made the unit will display "REFERENCES NOT CHANGED."

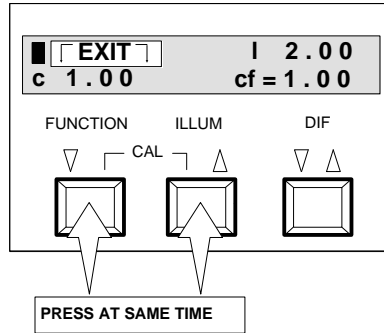

Taking a CMC Difference Measurement

Before a CMC difference measurement can be made:

- LCh CMC must be set to "ON" in modes (Sec. 5.2)
- Reference must be entered (Sec. 3.5.1)
- CMC difference operation must be setup (Sec. 3.6).

- 1) Select desired illuminant/observer (see Sec. 3.3).
- 2) Select $L^*C^*h^\circ$ difference mode function.
- 3) Center target window over area to be compared.
- 4) Lower unit to target window and hold compressed. "Reading $L_cC_cH_c C^2$ " (i.e., the selected illum/obs) will momentarily be displayed, and then the reference location and data. Release the unit.

- 5) The display will show the difference between the reference color and sample, and the ΔE_{CMC} value.

- Pressing the **[DIF]** key will toggle the display between the absolute measurement values and the CMC difference values.

CMC Difference Values

\hat{E}	.13	L_c	-.09
C_c	-.02	H_c	+.10

Absolute

$\frac{1}{3}L^*C^*h^\circ C^2$	L^*	94.10
C^*	h°	344.06

-  > "CMC of TOLERANCE EXCEEDED" will display during a $L^*C^*h^\circ$ difference measurement when ΔE_{CMC} value exceeds the cf (commercial factor) value.
 > $L_cC_cH_c$ are values used for calculating ΔE_{CMC} and are not ΔL^* , ΔC^* , and ΔH^* .

3.7 Measurement Averaging Procedure

When averaging is activated in setup, averaging operation will occur on absolute measurements, reference entry measurements, and difference measurements.

There are two averaging methods that are used: (refer Sec. 5.1 to activate averaging):

- **SAMPLES AVERAGED** - allows you to enter the number of measurements you will make (1-99) at various locations on a sample, to obtain an average value.
- **SUB AVERAGE** - allows you to enter the number of measurements the unit will take (1-6) on a sample at a single location, to obtain an average value.



> When average and sub average are set to one, no averaging is performed and no averaging messages will be displayed.

The following example was taken in the absolute measurement mode using: XYZ function, two sub averages, and two measurement averages.

- 1) Press **[FUNCTION]** to select XYZ measurement space.

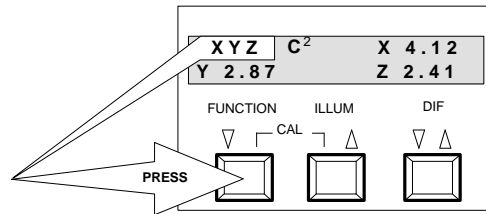

- 2) Center the target window over first area on the sample to be measured.

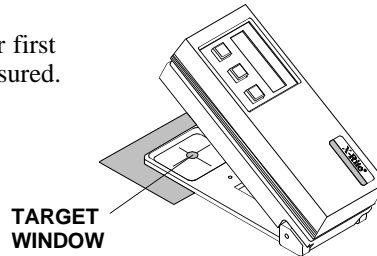

- 3) Lower unit to target window and hold compressed. "READING XYZ C² 1 OF 2", "2 OF 2", and the data is display.

After releasing the read head, "MEASURE SAMPLE 2 OF 2" is displayed.

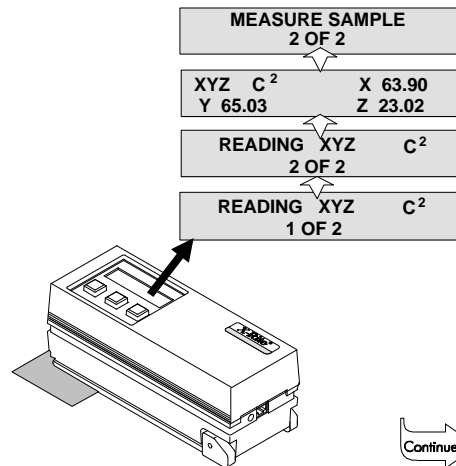

- 4) Center the target window over second area on the sample to measure.

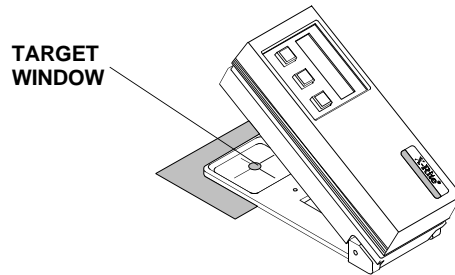

- 5) Lower unit to target window and hold compressed. "READING XYZ C² 1 OF 2" and "2 OF 2" will momentarily be displayed, and then the averaged data.

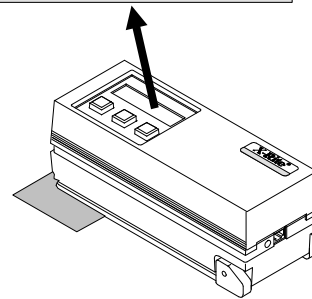
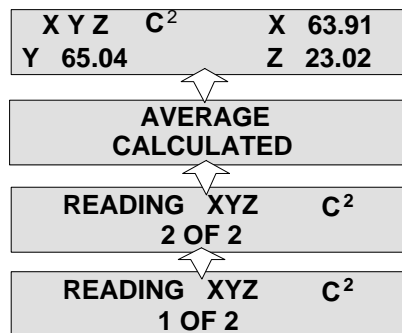

- 6) The display will show the average absolute values for XYZ.

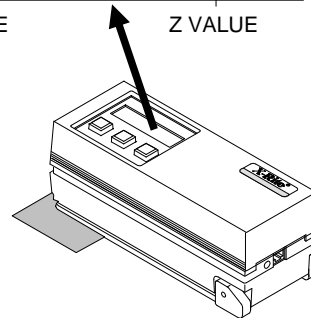
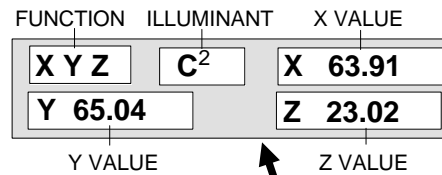

- > Do not jar or lift reading head during sub averaging measurements.
- > Refer to Section 5.1 averaging setup procedure.
- > When averaging is activated, this basic procedure must also be followed during reference measurements and difference measurements.

3.8 Store Data Operation

The data storage feature allows the unit to store measurement data for up to 500 readings. (Refer to Sec. 5.4 to activate.)

There are four basic operations of the store data function that can be utilized in the store data function.

- **Group Selection** - group tagging allows you to assign group numbers to the stored values. Group tagging is only accessible through RCI with a software package such as SpectroStart.
- **Send data** - allows all of the stored data to be transferred to a computer or serial printer. Data is sent as determined by the function displayed and modes enabled.
- **Delete last** - allows only the last measurement data to be deleted from stored memory.
- **Clear all** - causes all of the measured data in stored memory to be deleted.

The following sample (made in XYZ absolute) illustrates the different functions of the data storage feature.

MEASUREMENT

- 1) Press **[FUNCTION]** to select XYZ measurement space.

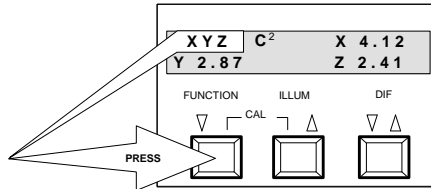

- 2) Measure first sample.

"READING XYZ C²" is momentarily displayed, then the measurement.

Upon release of the read head, "DATA STORED 1 OF 500" and then the measurement is displayed.

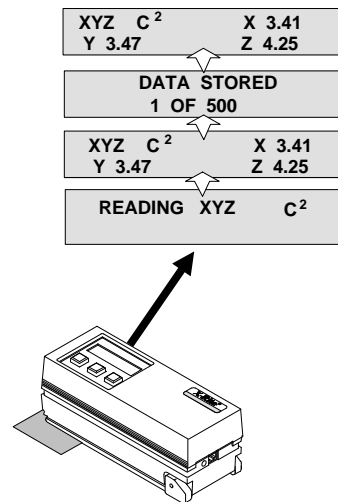

Continued

3) Measure second sample.

"READING XYZ C²" is momentarily displayed, then the measurement.

Upon release of the read head, "DATA STORED 2 OF 500" and then the measurement is displayed.

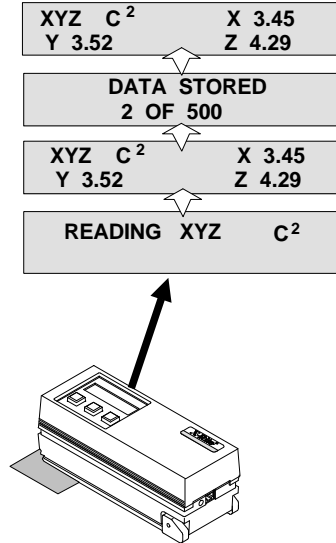

SEND DATA

4) Press both [ILLUM] and [DIF] at the same time.

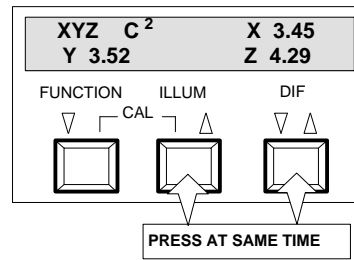

5) Press [DIF] to transfer data (go to Step 7).
If "NO" is selected, press [FUNCTION] and advance to Step 6.

Sample Printout

XYZ	C_2	#0001				
X	3.41	Y	3.47	Z	4.25	
XYZ	C_2	#0002				
X	3.45	Y	3.52	Z	4.29	

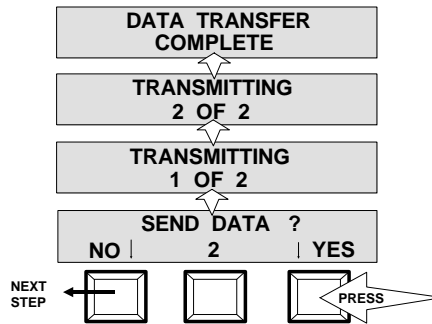

DELETE LAST MEASUREMENT

- 6) Press **[DIF]** to delete the last measurement made (this step can be repeated to delete several of the last measurements).
If "NO" is selected, press **[FUNCTION]** and advance to Step 7.

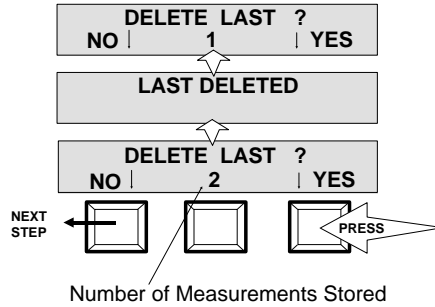

CLEAR ALL DATA

- 7) Press **[DIF]** to clear all stored measurement data taken.
If "NO" is selected, press **[FUNCTION]** to return to normal operation.

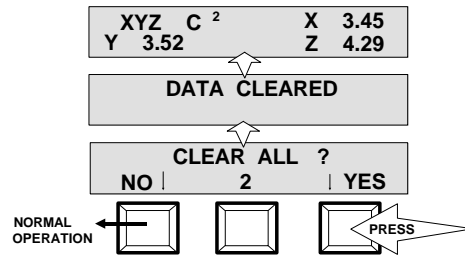

-  > The Send/Clear data function may be exited at anytime by pressing **[FUNCTION]** and **[ILLUM]** at the same time.
> Refer to Section 5.4 to activate the store data function.
> "STORAGE FULL" will display on all measurements after 500 stored measurements has been reached

3.9

Display Messages

The most likely reasons for error messages to display are described below. If an error message is consistently displayed, contact X-Rite or an Authorized Service Center.

Power-Up Messages

"**MEMORY LOST**" is displayed when the instrument determines that the data in the (battery backed up) RAM has been corrupted, if the internal lithium battery on the P.C.B. is bad, or if a new EPROM has been installed.

Operational Messages

"**CMC of TOLERANCE EXCEEDED**" is displayed during a L*C*h° difference measurement when ΔE_{CMC} value exceeds the cf (commercial factor) value.

"**C² ONLY FOR - YELLOWNESS**" is displayed when trying to select an illuminant other than C² for Yellowness.

"**INVALID READING**" is displayed when the unit is not held down long enough during a measurement.

"**NEED CALIBRATION**" is displayed if the calibration procedure is not performed for 24 hours, or if there is a 10°C change in temperature since the last calibration.

"**READING COMPLETE**" measurement has been taken and the instrument can be released.

"**READING XYZ C²**" is displayed during a measurement. XYZ can be any of the functions and C² can be any of the illum/obs combinations.

"**REFERENCES - NOT CHANGED**" is displayed after leaving the Reference Entry function, and no change was made.

"**REFERENCES UPDATED**" is displayed when [FUNCTION] and [ILLUM] are simultaneously pressed, when exiting reference mode.

"**SELECT ILLUMINANT**" is displayed when the [ILLUM] key is held down for three seconds, activating illuminant selection.

"**SET REF VALUES - ENTER or MEASURE**" is displayed if the difference mode is on, and the [DIF] key has been held down for three seconds, activating reference entry mode.

"**SET REF VALUES - MEASURE ONLY**" is displayed in Δ WHT and Δ YEL when reference entry mode is enabled. You can only enter these reference values by measurement.

"**UPDATING REFS ## - CLEAR REFS↓**" when the illuminant/observer is changed the stored references are automatically updated. This message also allows you to clear out all stored references (see Section 3.3 for more details).

"**USE ANOTHER COLOR SPACE**" is displayed when you try to enter the reference value numerically in Δ WHT and Δ YEL. You can only enter the reference values by measurement.

Calibration Messages

"**CALIBRATION - FAILED**" is displayed when making a calibration measurement and something is wrong (invalid reading or data is out of range).

- "CALIBRATION - NOT CHANGED"** is displayed when the user decides to terminate the calibration procedure by simultaneously pressing **[FUNCTION]** and **[ILLUM]**.
- "CALIBRATION - UPDATED"** is displayed after the calibration procedure has been successfully completed.
- "CAL ERROR ### - CELL CHANGE"** make sure that calibration plaque is clean and instrument is positioned exactly on the white spot. If the error persists, the number that is displayed should be reported to X-Rite or an authorized service center.
- "CAL ERROR ### - MOTION DETECTED"** calibration requires that the instrument remain motionless during the five measurements of the white spot. If the error persists and is not due to movement, the number that is displayed should be reported to X-Rite or an authorized service center.
- "INVALID ENTRY"** is displayed when the numbers entered for the white values are inappropriate.
- "INSUFFICIENT READINGS"** indicates that all sub-average readings were not made.

Miscellaneous Messages

- "BATTERIES LOW"** indicates that the batteries are getting low and will soon need to be charged. It will only be displayed while the measurement is in progress. Once displayed you will have approximately 100-200 measurements remaining before charging is mandatory.
- "BATTERIES MUST - BE CHARGED"** indicates that the batteries are too low to operate the unit. It will be displayed until you begin the recharge cycle, thereafter, the unit will be functional and all previous data will be accessible.
- "I/O NOT READY - check I/O PIN 5"** is displayed when I/O pin 5 is set to "CTS" in modes and the unit is not connected to a printer or computer. Set handshake to "OFF" if unit is not connected to a printer or computer.
- "LAMP FAILURE"** measurement lamp is bad. The lamp should be replaced by X-Rite or an authorized X-Rite service center. When this message occurs, you can get out of this condition by pressing **[FUNCTION]** then **[ILLUM]** then **[FUNCTION]**; or waiting until the unit powers down.
- "READING ERROR ##"** reading error due to hardware problem. If this message persists the number that is displayed should be reported to X-Rite or an authorized service center.
- "REFL. EXCEEDED"** calculation of reflectance for at least one of the 20nm segments was more than 200%. This is usually caused by a bad calibration procedure. Recalibrate unit.
- "THANKS! - I NEEDED THAT!"** indicates that the charger has been plugged in and the batteries are being charged. This is in response to the message "BATTERIES MUST BE CHARGED".
- "WEAK LAMP - REPLACE SOON"** indicates that the lamp is getting weak and should be replaced in the near future. When this message occurs, you can get out of this condition by pressing **[FUNCTION]** then **[ILLUM]** then **[FUNCTION]**; or waiting until unit powers down.
- "X-Rite VER#### - COPYRIGHT 1990"** is displayed when first activating calibration. #### represents the datecode of the software.

4. Calibration

The 948 & 968 should be calibrated to the X-Rite standard the first thing each day and every four hours of operation thereafter. However, a "NEED CALIBRATION" message will appear in the display:

- If the calibration procedure has not been performed for 24 hours.
- If there is a 10°C change in temperature since the last calibration.
- If zero reflectance is measured improperly.
- If the lamp output changes.

Whenever this message appears the calibration procedure should be performed before another measurement is taken to ensure accuracy.

Important Calibration Notes

- **If you change apertures you must change the aperture setting, read zero reflectance, & calibrate the unit** (see Section 4.2, steps 1, 2, & 5a thru 5d).
- Dirt or dust in the optics area will cause an inaccurate calibration reading. Refer to Section 8.2 for the optics cleaning procedure.
- **The ceramic Reflection Standard is dramatically affected by smudge marks, dust, and finger prints.** The standard should be cleaned using a mild soap and warm water solution, thoroughly rinsed with warm water, and wiped dry with a lint free cloth. You must let the standard dry completely before taking a calibration reading.
- If you are having linearity problems it's possible that there is dust in the optics or Zero Reflectance has drifted. If you improperly measure Zero Reflectance the unit can not automatically detect the drift. If you suspect this is the case, you should manually activate Read Zero Reflectance by performing Steps 1, 2, & 5 of Section 4.2.
- Do not move the 948/968 while taking a calibration measurement. If motion is detected an error message will be displayed and calibration aborted.

4.1 Positioning the 968 Onto the X-Rite Standard

You must set the 948/968 on the white standard so that the maximum amount of the bottom rubber pad of the shoe resides on the standard, and the target is centered on the circle. If you do not, the unit may rock slightly and cause an erroneous reading of the standard.

- 1) Center the target window on the White circle, making sure that the rubber pad is completely on the standard **and is down flat**.

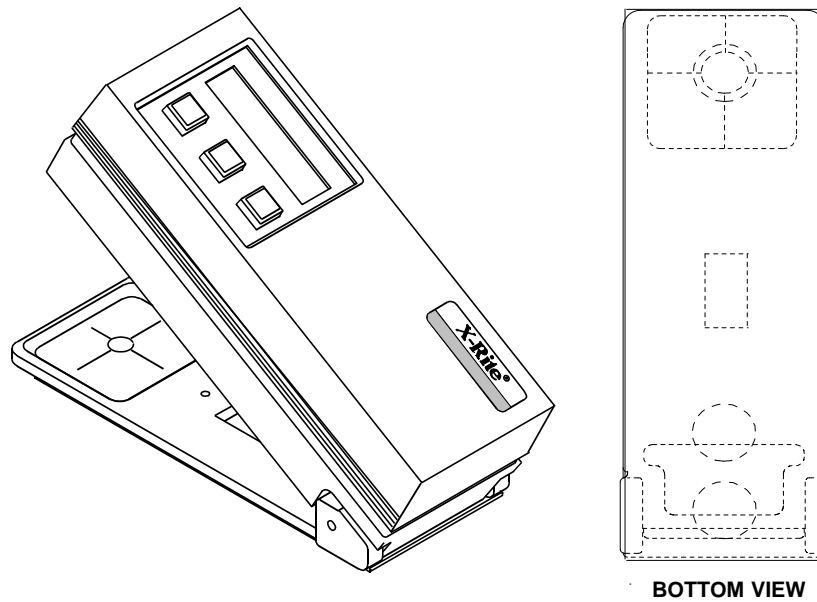

- 2) Take the measurement.



Shown below is an **IMPROPER METHOD** of measuring the standard.

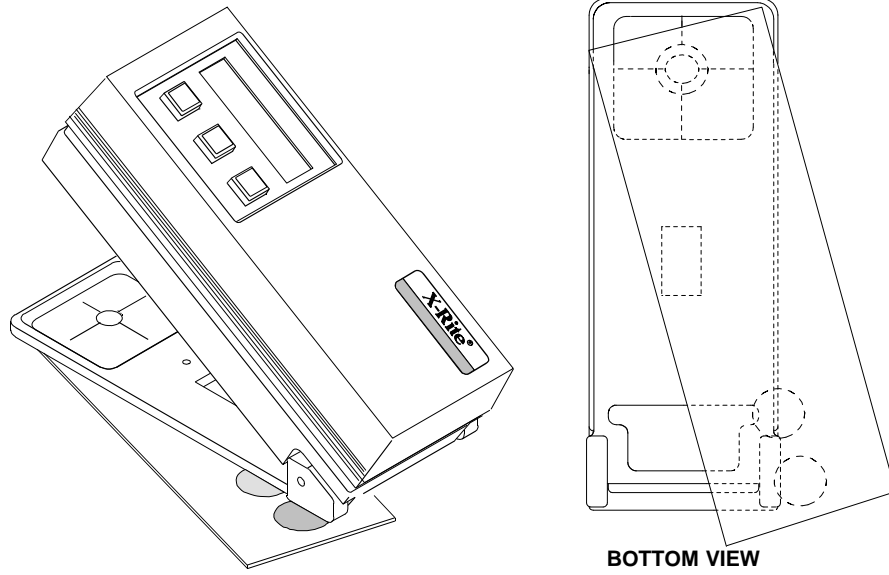

INCORRECT!

X-Rite Reflection Standard

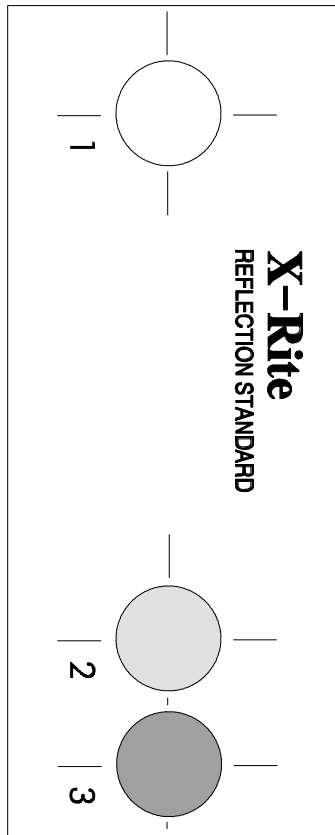

X-Rite®
 Reflection Standard
 P/N 968-62
 Serial No. CXXXXXXXXP-XXXXX
 Date XX/XX/XX

WAVE [nm]	REFL [%]
390	62.10
400	76.70
410	81.88
420	85.02
430	85.99
440	86.12
450	86.48
460	86.74
480	87.05
500	87.42
520	87.36
540	87.08
560	86.72
580	86.25
600	85.71
620	85.18
640	84.52
660	84.02
680	83.35
700	82.69
710	81.99

CALIBRATION CHECK	
C/2 (WHITE)	
L*	
a*	
b*	

Instrument Model No. _____

Instrument Serial No. _____

COLOR CHECK

Refer to section in operation manual appendix for procedure to obtain reference values.

DATE: _____ TEMP: _____

ILLUM/OBS: _____ APERT: _____

REFERENCES VALUES			
STEP	L*	a*	b*
1 (White)			
2 (Blue)			
3 (Brown)			

Notes: _____

IMPORTANT!
 The standard is dramatically affected by smudge marks and dust; and must be kept clean.

The Calibration Values for the white spot are affected by the environment and cleaning method of the standard.

If the white spot does not measure correctly, it could be that the unit needs to be calibrated; there is dust in the optics; or the standard has smudge marks or is dirty.

The ceramic standard should be cleaned using a mild soap and warm water solution, thoroughly rinsed with warm water, and wiped dry with a clean, lint free cloth.

If you lose your envelope, you can obtain the calibration values from the back page of this manual, or, by looking at them in the calibration procedure. Otherwise, you can contact X-Rite with the serial number of your standard and get the values.

4.2 Calibrating to the White Standard

 > If you are changing aperture size: Do steps 1, 2, & 5a thru 5d. Skip steps 3 & 4.

- 1) Press both [FUNCTION] and [ILLUM] at the same time.

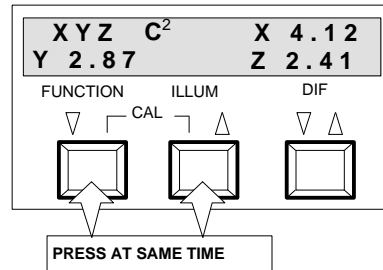

- 2) Select "YES", press [DIF].

The copyright and software version are momentarily displayed.

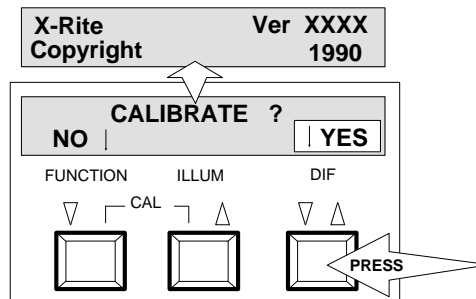

- 3) "READ CAL WHITE" is displayed. At this point you have two options:

- You can measure the white spot on the standard (go to step 4). **This is standard operating procedure.**
- Or, you can press [CHANGE] to change the calibration values for the 21 different spectral values or to change the aperture setting. **This procedure is only used when you want to calibrate to a different standard or you change apertures.** Go to step 6.

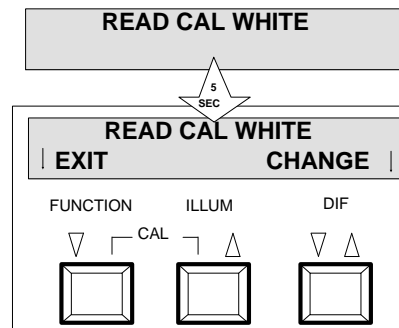

 Continued

4) Measure the WHITE patch on the standard. You must hold the unit depressed until all five readings have been completed.

 > You must set the unit on the standard so that the maximum amount of the bottom rubber pad of the shoe resides on the standard (refer to Section 4.1).

"CAL READING 1 OF 5" thru "CAL READING 5 OF 5" is displayed; then "CALIBRATION UPDATED." The procedure is finalized and the unit returns back to main menu.

-  > During the Cal Reading, the read head must remain down and stable or an error message may occur.
- > If "PLEASE WAIT XX (1-30) SECONDS" is displayed during calibration, continue to hold read head down until calibration readings are over. This will only occur if the calibration procedure is performed within 30 seconds of a previous measurement.
 - > If "READ ZERO REFLECTANCE" is displayed after reading the white spot, go to step 5. This will only occur if the calibration values for zero reflectance have drifted.

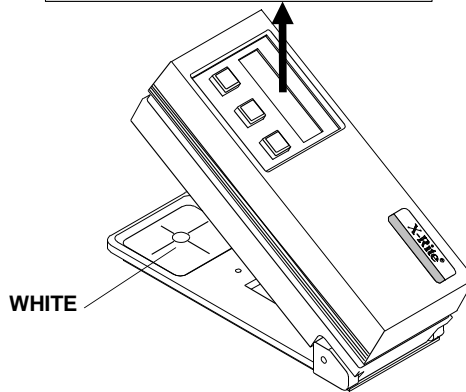
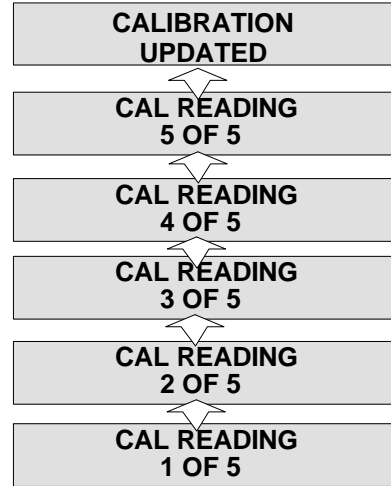

THE FOLLOWING STEPS (5 & 6) ARE ONLY NECESSARY IF YOU WANT TO MEASURE ZERO REFLECTANCE, CHANGE SPECTRAL VALUES, or CHANGE APERTURE SIZE.

5) Steps 5a - 5d are only necessary if "READ ZERO REFLECTANCE" is displayed, you want to manually activate Zero Reflectance Measurement, or YOU WANT TO CHANGE APERTURE SIZE.

Zero Reflectance is defined as, "measuring air with no ambient light".

This can be accomplished by holding the unit depressed (take a reading) in a dark room. In some cases, it is possible to just take a reading under a desk with no direct light.

To manually activate zero reflectance measurement or you want to change aperture size, see next page.



5a) Press [CHANGE].

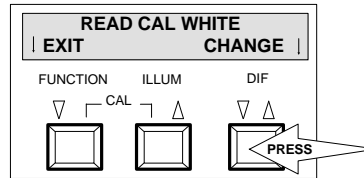

5b) Press [NO].

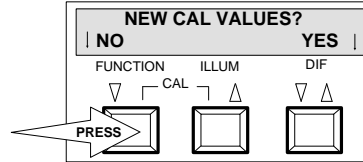

5c) Press [NEXT] if the aperture size is correct (go to step 5d).

If the aperture size is wrong press [DIF] to change size.

- > If you change aperture size you will be sent back to step 5a after pressing [NEXT]. At that point you must read Cal White, then Zero Reflectance.

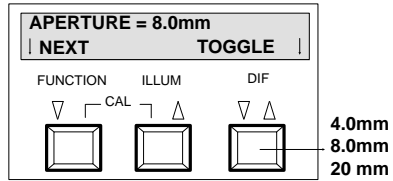

5d) Measure Zero Reflectance.

- > You must measure Cal White after Zero Reflectance, if you manually selected Zero reflectance



6a) Steps 6a - 6c are only necessary if you want to change the 21 spectral calibration values.

Press [YES]

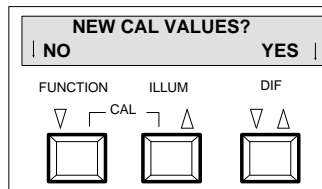

6b) Enter the value for 390nm.

- > The [DIF] key advances the cursor to the next value to be edited.
- > Hold [DIF] depressed then press [▼] to decrease value or [▲] to increase value.

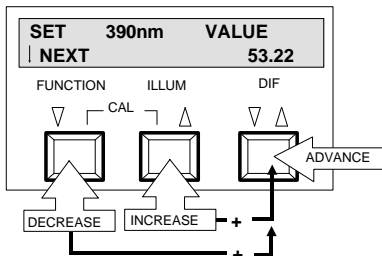

6c) After entering value press [FUNCTION] to advance.

- Enter the value for 400nm.
- Repeat procedure for all values
- After entering all 21 spectral values go back to step 4.

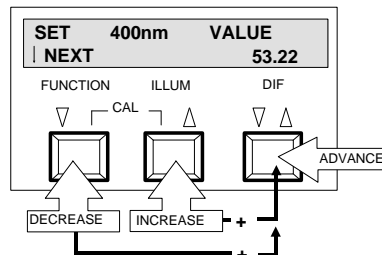

5. Setting System Parameters

5.1 Averaging

The averaging feature allows the unit to make several measurements from the same and/or different locations on a sample. This will allow you to have a better overall average of a sample color. The averaging feature has two functions:

- **SAMPLES AVERAGED** - allows you to enter the number of measurements you will make (1-99) at various locations on the sample, to obtain an average value.
- **SUB AVERAGE** - allows you to enter the number of measurements the unit will take (1-6) on a sample at a single location, to obtain an average value.

 > When average and sub average are set to one, no averaging is performed and no averaging messages will be displayed.

-
- 1) Press both **[FUNCTION]** and **[ILLUM]** at the same time.

 > To exit Average Setup: Press **[FUNCTION]** and **[ILLUM]** at the same time and the unit will return back to normal operation.

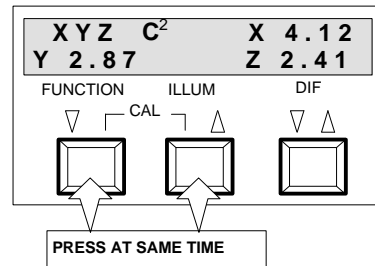

-
- 2) Select "NO", press **[FUNCTION]**.

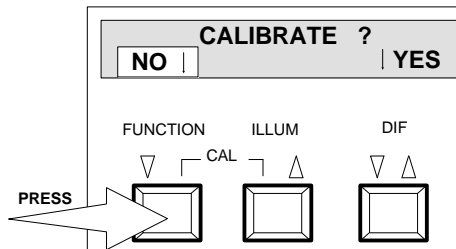

- 3) Select "YES", press [DIF].

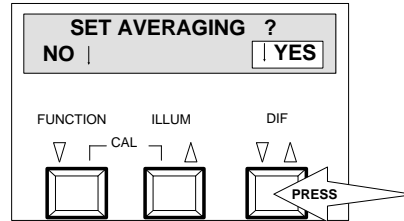

- 4) Select the amount (1-99) of sample measurements required.

- Hold down [DIF] and press [▼] to decrease the sample measurement number or press [▲] to increase the sample measure number.
- Press [FUNCTION] to advance to the Sub Average number entry.

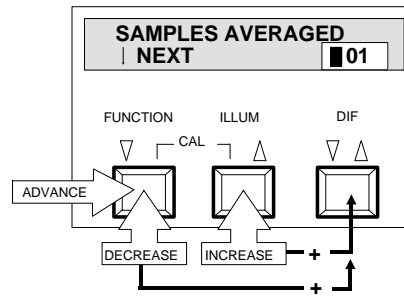

- 5) Select the amount (1-6) of sub average measurement required.

- Press [DIF] to select sub average number.

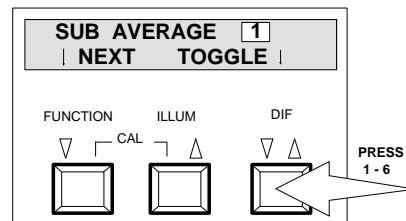

- 6) Press [NEXT] to return to "SET AVERAGING?" Menu. Or, press [FUNCTION] and [ILLUM] at the same time to exit to normal operation.

5.2 Operation Parameters

Operation setup allows you to select various options, and individually turn on/off certain functions. When a function is turned off it will not be displayed during operation.

- 1) Press both **[FUNCTION]** and **[ILLUM]** at the same time.

 > To exit Operation Setup: Press **[FUNCTION]** and **[ILLUM]** at the same time and the unit will return back to normal operation.

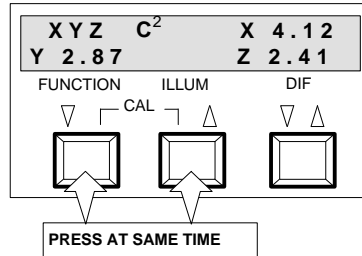

- 2) Select "NO", press **[FUNCTION]** twice.

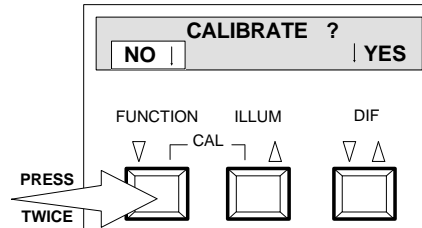

- 3) Select "YES", press **[DIF]**.

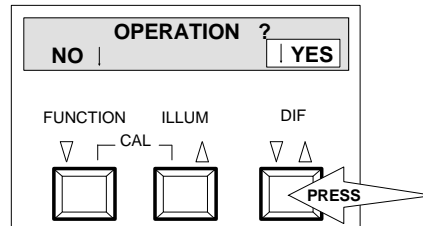

The procedure for the following steps is to press **[TOGGLE]** to change an option, or to turn a particular function on or off. Press **[NEXT]** to advance to the next step.

- 4) Select tone **SOFT TONE**, **LOUD TONE**, or **TONE OFF**.

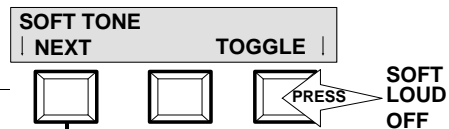

- 5) Select **XYZ ON**, **X%Y%Z% (RGB) ON**, or **OFF**.

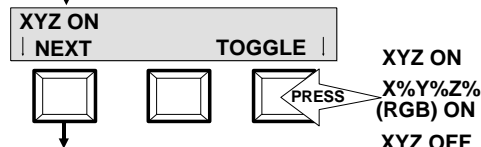

 Continued

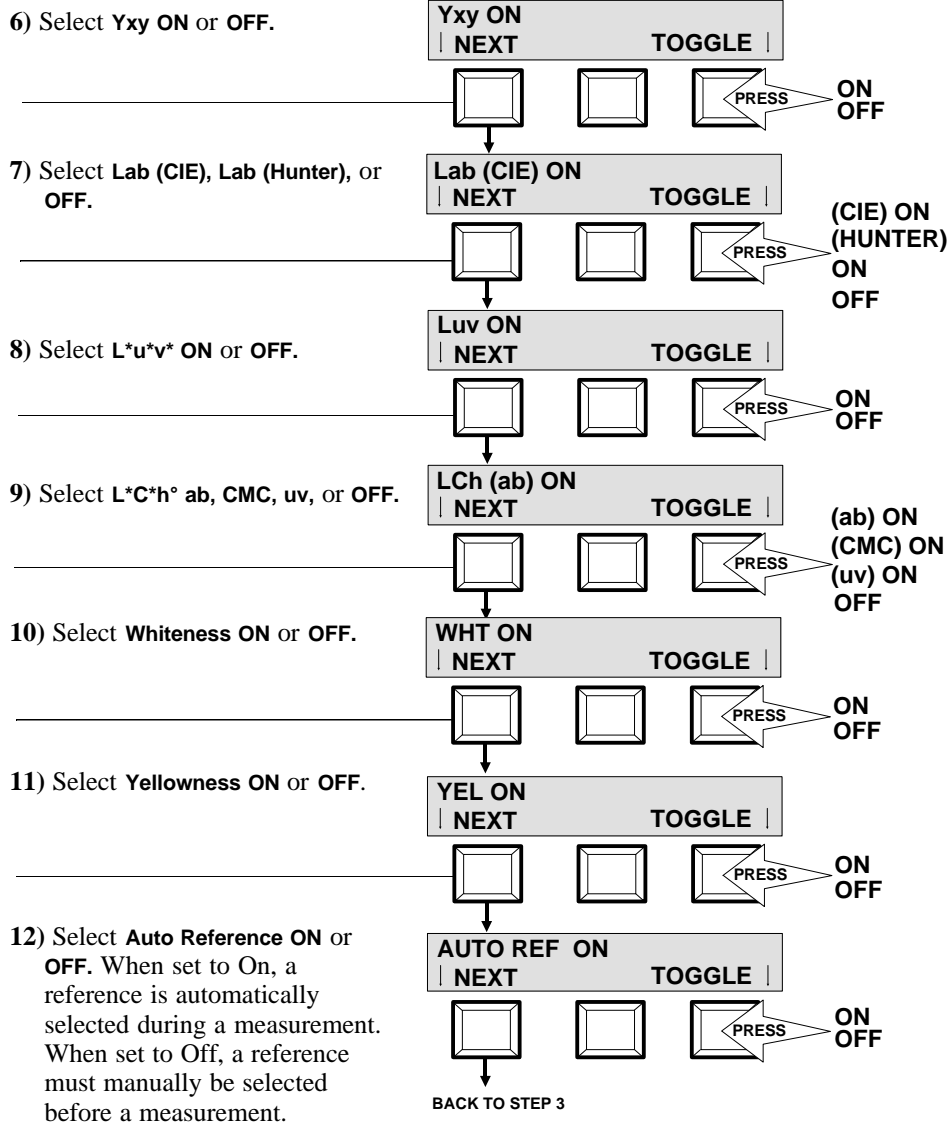

 > Exit via **[NEXT]** OR press **[FUNCTION]** & **[ILLUM]** at the same time to return back to normal operation.

5.3 RS232 I/O Parameters

Your instrument comes equipped with a serial port that allows data to be transmitted/received to/from an external device. Listed below are the available I/O parameters.

- **"RCI ON/OFF"** (Remote Control Interface) - enables or disables the ability to externally control the 948/968 via the I/O port.
- **"BAUD"** - determines the input/output rate (characters per second) of the I/O port. Available outputs are: 300, 600, 1200, 2400, 4800, and 9600.
- **"CR WITH LF/CR WITH NO LF"** (Carriage Return with Line Feed/Carriage Return with no Line Feed) - varies the delimiter at the end of each line of data. When set to CR WITH NO LINE FEED, just a Carriage Return is sent at the end of a line of data. When set to CR WITH LF, a Carriage Return and then a Line Feed are sent at the end of a line of data.
- **"HANDSHAKE"** is used for data transmission. Handshake may be set to HANDSHAKE OFF (ASCII = 13H), PIN 5 CTS (Clear to Send), PIN 5 BUSY, or XON/XOFF ENABLED (ASCII = 11H). Handshake should normally be set to OFF when it is not being used.

1) Press both **[FUNCTION]** and **[ILLUM]** at the same time.

 > To exit I/O Setup: Press **[FUNCTION]** and **[ILLUM]** at the same time and the unit will return back to normal operation.

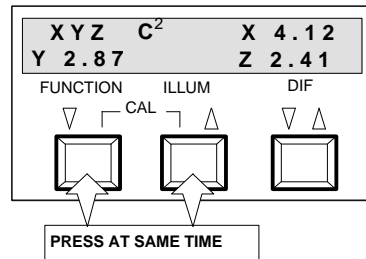

2) Select "NO", press **[FUNCTION]** three times.

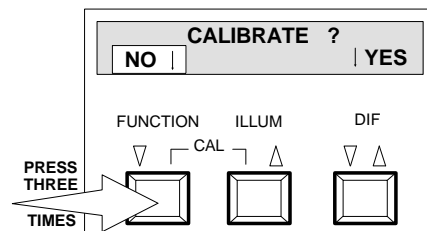

 Continued

3) Select "YES", press [DIF].

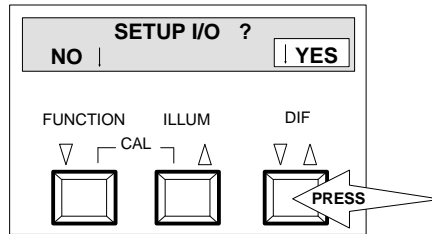

> The basic procedure for the following steps is to press [TOGGLE] to set the I/O parameter. Press [NEXT] to advance to the next step.

4) Select RCI ON or OFF.

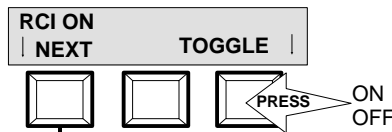

5) Select the BAUD Rate.

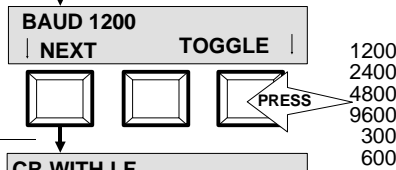

6) Select Carriage Return with or without Line Feed.

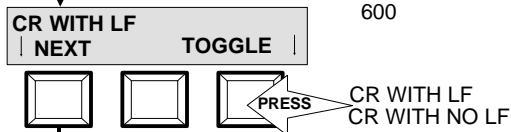

7) Select HANDSHAKE OFF, PIN 5 CTS, PIN 5 BUSY, or XON/OFF ENABLED.

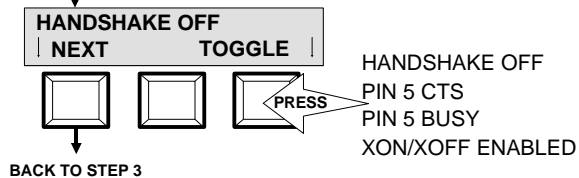

Exit via [NEXT] OR press [FUNCTION] & [ILLUM] at the same time to return back to normal operation.

5.4 Format Output Parameters

This procedure allows you set the output format of the RS232 port. Refer to Section 6 for sample print outs. Listed below are the available options.

- **AUTO PRINTOUT/STORE DATA/PRINTOUT OFF** - determines if data will be transmitted after each measurement, stored until transmitted, or not allow data transfer.
 - AUTO PRINTOUT** - enables the unit to transmit data after each measurement.
 - STORE DATA** - allows the unit to store up to 500 measurements.
 - PRINTOUT OFF** - disables the ability to output data via the RS232 port from a reading.
- **COMPUTER/PRINTER/SPECTRAL** - selects the output format of the data being transmitted.
 - COMPUTER FORMAT** (used for wide printers) - transmits a group of data values per line of print (see Section 6, Print Example 2).
 - PRINTER FORMAT** (used for narrow printers) - transmits a group of data values in a single column format (see Section 6, Print Example 1).
 - SPECTRAL FORMAT** (968 ONLY) - transmits the measurement values for each wavelength (400nm - 700nm) in 10 nanometer increments (see Section 6, Print Examples 4 & 5).
- **ALL PRINT OFF/ON** - determines which functions (XYZ, Yxy, etc.) are transmitted. When set to OFF, only the active function will be transmitted. When set to ON, all the functions that are turned on in the "Operation Parameters" are transmitted.
- **PRINT HEADER OFF/ON** - enables or disables the header (XYZ, Yxy, etc.) during transmit.
- **PRINT REF OFF/ON** (Reference) - disables or enables the Reference values during transmit.
- **DEC. POINT ON/OFF** (Decimal Point) - enables or disables the decimal point during transmit.

- 1) Press both **[FUNCTION]** and **[ILLUM]** at the same time.

 > To exit Format Setup: Press **[FUNCTION]** and **[ILLUM]** at the same time and the unit will return back to normal operation

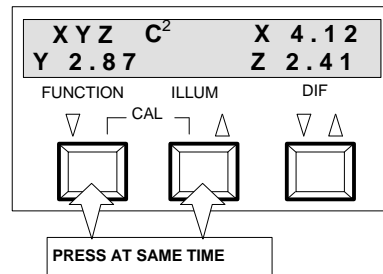

 Continued

- 2) Select "NO", press [FUNCTION] four times.

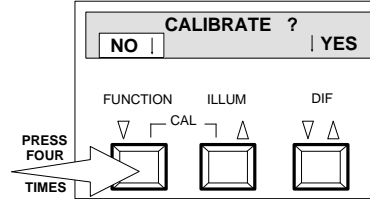

- 3) Select "YES", press [DIF].

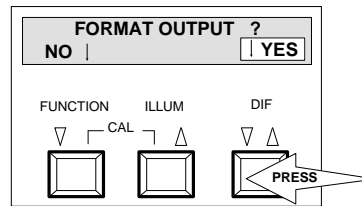

> The basic procedure for the following steps is to press [TOGGLE] to set the format. Press [NEXT] to advance to the next step.

- 4) Select Auto Printout, Store Data or Printout Off.

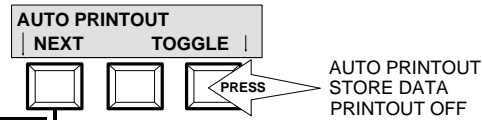

- 5) Select Computer, Printer, or Spectral.

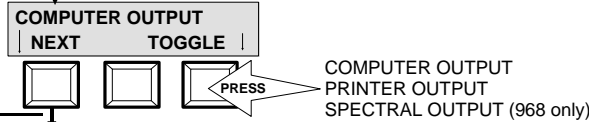

- 6) Select All Print OFF or ON.

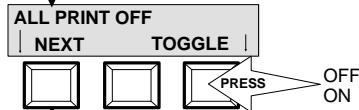

- 7) Select Print Header OFF or ON.

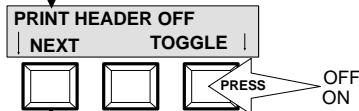

- 8) Select Print Reference OFF or ON.

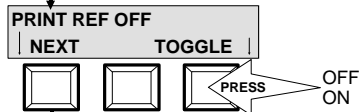

- 9) Select Decimal Point ON or OFF.

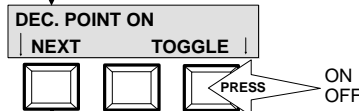

> Exit via [NEXT] OR press [FUNCTION] & [ILLUM] at same time.

BACK TO STEP 3

6. Printing Data

The RS232 parameters for the 948/968 serial interface are configured in Section 5.3. The variables are:

- Remote Control Interface (On/Off)
- Baud Rate (300, 600, 1200, 2400, 4800, or 9600)
- Carriage Return (With or Without Line Feed)
- Handshake (Off, Pin 5 CTS, Pin 5 Busy, or XON/XOFF Enabled)

The manner in which output data is arranged is determined by the Format Output Parameter settings in Section 5.4. The variables are:

- Printout (Auto, Store Data, Off)
- Output Type (Computer, Printer, Spectral)
- All Print (On/Off)
- Print Header (On/Off)
- Print References (On/Off)
- Decimal Point (On/Off)

Data is transmitted from the serial port after each measurement if "Printout" is set to Auto. The display will show "**TRANSMITTING DATA**" while transmission is taking place, and then return back to normal operation.

The following three pages contain some examples of the different types of outputs that can be obtained according to the Format Output Parameter settings.

Print Example 1:

- Printer ON
- All Print ON
- Header ON
- References ON
- Decimal Point ON

- > If **Header, References,** or **Decimal Point** are turned OFF, they will not print.
- > If All Print is OFF, only the data for the active color space will print.

d(XYZ) C_2	HEADER
X +.58	COLORIMETRIC DATA
Y -.28	
Z +1.15	
REF 01	REFERENCE DATA
X 75.00	
Y 60.92	
Z 27.99	
d(Yxy) C_2	
Y -.28	
x -.0005	
y -.0050	
REF 01	
Y 60.92	
x .4596	
y .3717	
d(L*a*b*)C_2	
L -.16	
a +1.86	
b -1.95	
E 2.70	
REF 01	
L 82.34	
a +33.36	
b +45.83	
d(L*u*v*) C_2	
L -.16	
u +2.30	
v -2.57	
E 3.45	
REF 01	
L 82.34	
u +84.24	
v +53.74	
d(L*C*H*) C_2 (ab)	
L -.16	
C -.41	
H -2.67	
REF 01	
L 82.34	
C 56.68	
H 53.88	
d(WHT) C_2	
We +4.69	
W +8.62	
T -2.65	
REF 01	
We -87.47	
W -115.43	
T -111.43	
d(YEL) C_2	
Ye -56.39	
Yd -99.70	
REF	
Ye +61.08	
Yd +108.32	

Print Example 2:

- Computer ON
- All Print ON
- Header ON
- References ON
- Decimal Point ON

- > If **Header**, **References**, or **Decimal Point** are turned OFF, they will not print.
- > If All Print is OFF, only the data for the active color space will print - See Print Example 3, below.

d(XYZ) C_2	HEADER
X +.32 Y -.12 Z +.25	COLORIMETRIC DATA
REF 01	REFERENCE DATA
X 75.00 Y 60.92 Z 27.99	
d(Yxy) C_2	
Y -.12 x +.0007 y -.0018	
REF 01	
Y 60.92 x .4576 y .3717	
d(L*a*b*)	
L -.07 a +.97 b -.49 E 1.09	
REF 01	
L 82.34 a +33.36 b +45.83	
d(L*u*v*)C_2	
L -.07 u +1.43 v -.80 E 1.65	
REF 01	
L 82.34 u +84.24 v +53.74	
d(L*C*H*)C_2	
L -.07 C +.19 H -1.07 E 1.09	
REF 01	
L 82.34 C 56.68 H 53.88	
d(WHT) C_2	
We +1.00 W +2.38 T -1.87	
REF 01	
We -87.47 W -151.43 T -111.43	
d(YEL) C_2	
Ye -60.08 Yd -105.94	
REF 01	
Ye +61.08 Yd +108.32	

Print Example 3:

- Computer ON
- All Print OFF
- Header OFF
- References OFF
- Decimal Point ON

X .32 Y .12 Z .25

Print Example 4:

- Spectral ON
- All Print ON
- Header ON
- References ON
- Decimal Point ON

- > If **Header**, **References**, or **Decimal Point** are turned OFF, they will not print- See Print Example 5, below.
- > All Print does not affect the print out when Spectral in on.

SPECTRAL DATA	
W/WAVELENGTH	S 2.51
W	400.0 S 2.59
W	410.0 S 2.64
W	420.0 S 2.68
W	430.0 S 2.70
W	440.0 S 2.73
W	450.0 S 2.77
W	460.0 S 2.80
W	470.0 S 2.87
W	480.0 S 3.04
W	490.0 S 3.22
W	500.0 S 3.34
W	510.0 S 3.45
W	520.0 S 3.53
W	530.0 S 3.68
W	540.0 S 4.02
W	550.0 S 4.51
W	560.0 S 5.27
W	570.0 S 6.05
W	580.0 S 6.66
W	590.0 S 7.06
W	600.0 S 7.08
W	610.0 S 6.98
W	620.0 S 6.93
W	630.0 S 6.87
W	640.0 S 6.87
W	650.0 S 6.87
W	660.0 S 6.87
W	670.0 S 6.82
W	680.0 S 6.76
W	690.0 S 6.72
W	700.0 S 6.68

REFERENCE DATA	
	REF01
X	42.77
Y	43.48
Z	49.81

Print Example 5:

- Spectral ON
- All Print ON
- Header OFF
- References OFF
- Decimal Point ON

S	2.51
S	2.59
S	2.64
S	2.68
S	2.70
S	2.73
S	2.77
S	2.80
S	2.87
S	3.04
S	3.22
S	3.34
S	3.45
S	3.53
S	3.68
S	4.02
S	4.51
S	5.27
S	6.05
S	6.66
S	7.06
S	7.08
S	6.98
S	6.93
S	6.87
S	6.87
S	6.87
S	6.87
S	6.82
S	6.76
S	6.72
S	6.68

7. Changing Apertures

X-Rite has three different aperture kits available for the 948 & 968, and they are listed below.

- 8mm/4mm Aperture Kit P/N 968-100-08
- 8mm UV Excluded Aperture Attachment P/N 968-61-08E
- 20mm Aperture Kit P/N 968-100-20

Each aperture kit includes the aperture, sensor nose, extra target windows, and a specially designed aperture wrench.

APERTURE INSTALLATION

- 1) Unscrew the two thumb screws [1], then remove the nose piece [2].
- 2) *To install the 4mm aperture attachment;* screw the 4mm aperture attachment [3] onto the 8mm aperture [4]. **The 4mm aperture attachment must be screwed on finger tight;** then advance to Step 6 on following page.

To install the 8mm or 20mm aperture; advance to Step 3.

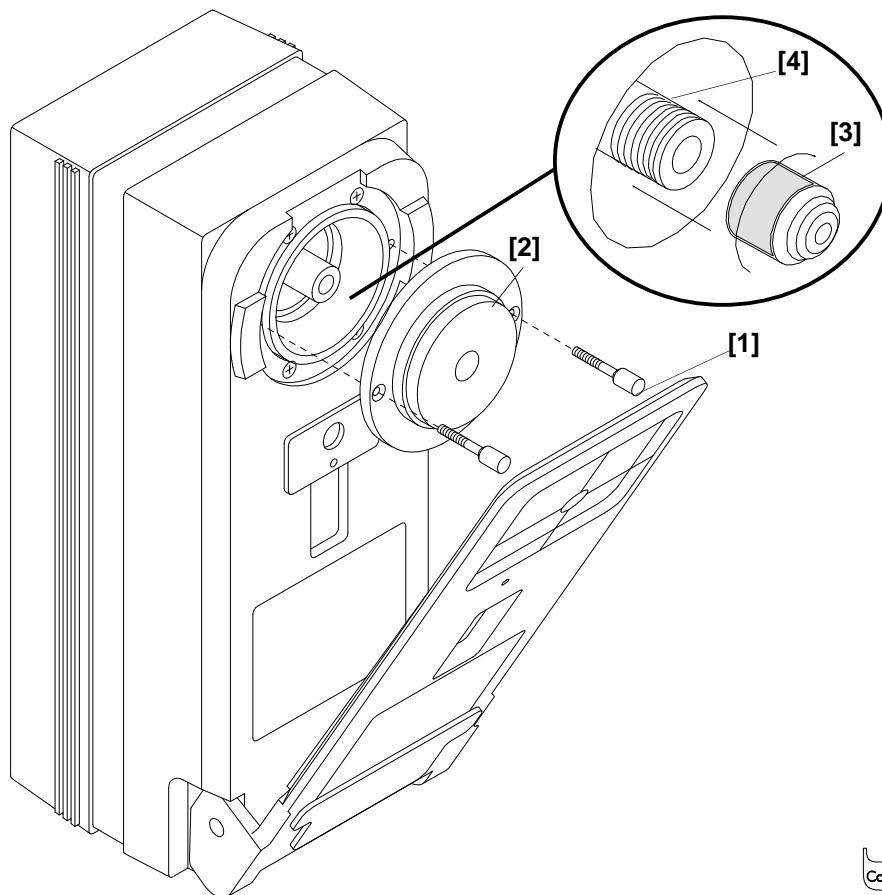

Continued 

- 3) Unscrew the existing aperture [5] with the aperture wrench [6].

Note: The aperture wrench tool has two sides, one side fits the 8mm aperture and the other fits the 20mm aperture.

The aperture wrench has two pins that fit into the holes in the aperture.

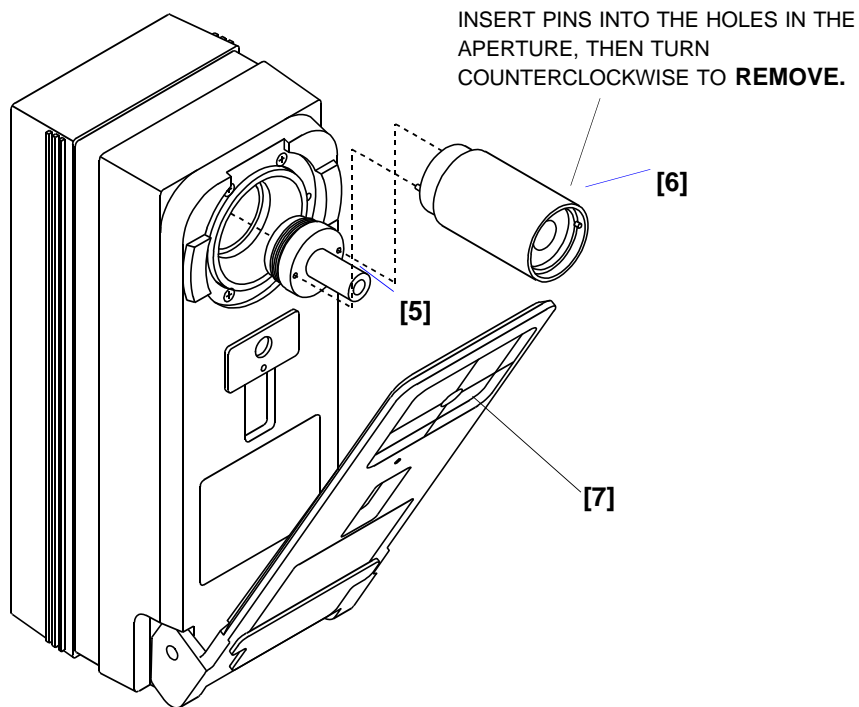

- 4) Screw in the new aperture using the aperture wrench.
IMPORTANT! The new aperture must be clean.

- 5) Attach the new nose piece to the housing with two thumb screws.
Note: When you tighten the thumb screws, be sure that the nose piece is flush against the housing. Gently tighten one screw, then the other. Then finish tightening both screws.

IMPORTANT! The new nose piece must be clean.

- 6) Replace the existing target window [7] with the new target window.
Refer to Section 8.4, Target Window Replacement for this procedure.

Note: If you switch back and forth between the 4mm and 8mm aperture, it is possible to use the 8mm target window with the 4mm aperture.

If you're very careful you can reuse the target window several times.

- 7) Change the aperture setting and recalibrate the unit.
Refer to Section 4.2, steps 1, 2, & 5a thru 5d for this procedure.

8. Maintenance

8.1. Troubleshooting

The X-Rite 948/968 is covered by a one year limited warranty (excluding ni-cad batteries) and should be referred to the factory or authorized service center for repair within the warranty period. Attempts to make repairs within this time frame may void the warranty.

X-Rite provides a factory repair service to their customers. Because of the complexity of the circuitry all circuit repairs should be referred to the factory or an authorized service center.

X-Rite will repair any 948/968 past warranty. Shipping costs to the factory or to an authorized service center shall be paid by the customer and the instrument shall be submitted in its original carton, as a complete unaltered unit.

CAUTION: DO NOT use any ketone solvents to remove ink from the unit. This will cause damage to the cover.

IMPORTANT! ALWAYS CHECK TO SEE IF READ LAMP IS WORKING BEFORE TROUBLESHOOTING.

-----TROUBLESHOOTING CHART-----

- A. If a wrong reading exists:
 - 1. Recalibrate unit.
 - 2. Clean Optics.
 - 3 Contact authorized service center.

- B. Unit does not turn on.
 - 1. Check for low batteries.
 - 2. Contact authorized service center.

- C. Display not working.
 - 1. Check for low batteries.
 - 2. Contact authorized service center.

- D. Reading Drifts.
 - 1. Clean Optics.
 - 2. Recalibrate unit.
 - 3. Contact authorized service center.

- E. Unit will not calibrate properly.
 - 1. Dirty reference.
 - 2. Optics dirty.
 - 3. Contact authorized service center.

8.2. Optics Cleaning

The target window and optics should be cleaned once a week in normal environments; and more often in dirty or dusty environments.

Target Window

1. Remove dust and lint from target window by wiping it with a clean, lint free cloth, slightly moistened with water.

Optics

1. Unscrew the two thumb screws [1] and remove the nose piece [2].
Remove dust from aperture with camel hair brush or a camera lens cleaner [3].

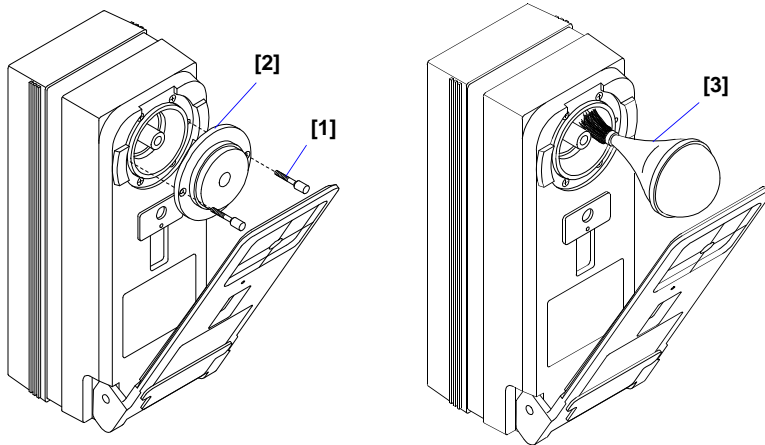

2. Blow short bursts of air into the optics opening using a camera lens cleaner (with the brush removed) until all dust is removed. This can be done with the nose piece removed or attached.



WARNING! Do not use an air can that uses freon as a propellant.
Doing so could cause damage to the optics assembly.

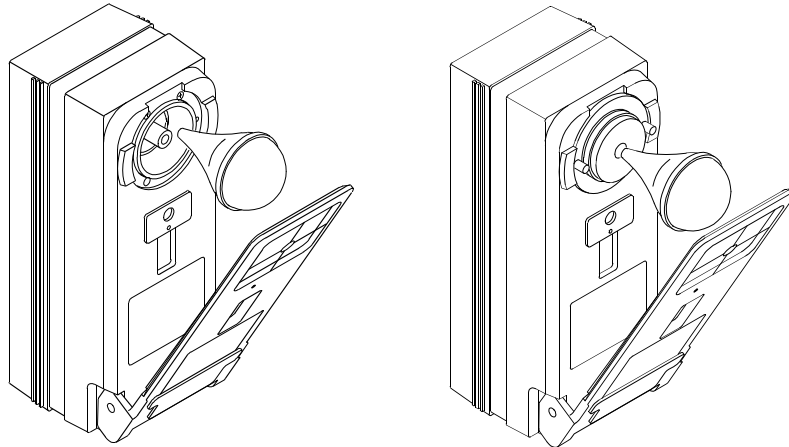

8.3. Battery Replacement

1. Set the 948/968 on it's side and lock shoe in place. The shoe must be locked.
2. Slide battery access door [1] toward bottom of unit and remove.
3. Disconnect plug [4] and pull battery pack [2] out of unit.
4. Remove old AA NI-CAD batteries [3], and install six fresh AA NI-CAD (recognizing proper polarity).
5. Slide battery pack [2] into unit, and reconnect battery plug [4]. Reinstall battery access door [1].
6. Unlock shoe.
7. Unit should be charged for 24 hours after new battery installation is performed.

Batteries P/N SE15-19 (6 Required)

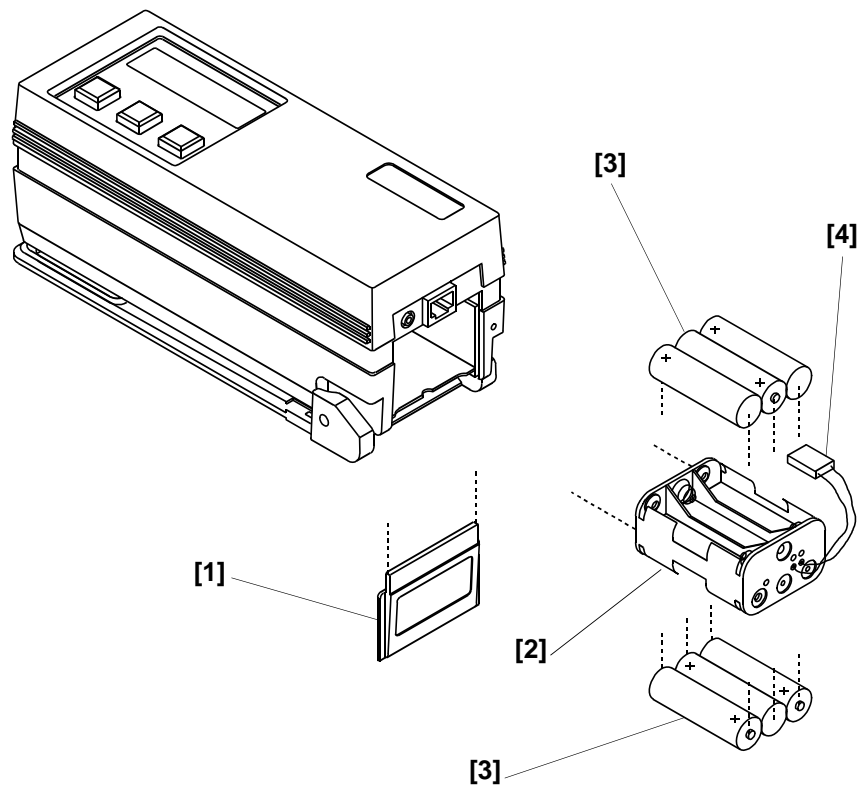

8.4. Target Window Replacement

1. Remove old target window [2] by pushing downward from top of shoe [1].
2. Place the instrument on end and align the target window so that the word "front" runs parallel with the top edge of the shoe [1].
3. Insert one edge (top or bottom) of the new target window [2] in the opening of the shoe [1].
4. Place the other side of the target window [2] in the shoe [1] by snapping into position.

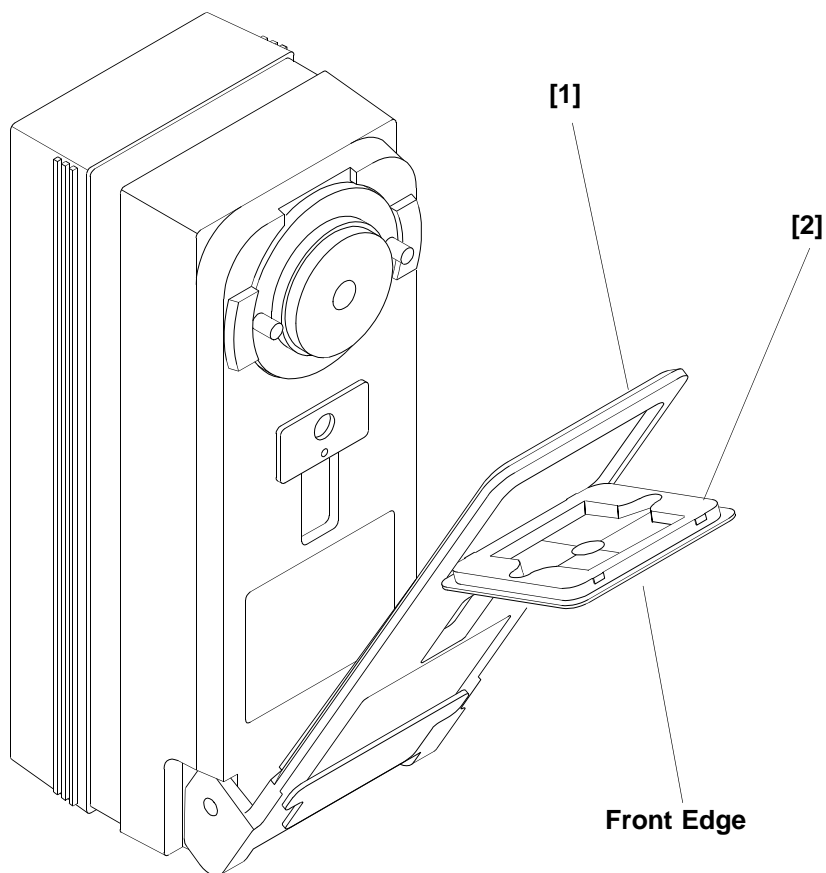

Target Window Part Numbers
968-121-20 (20mm)
968-121-08 (8mm)
968-121-04 (4mm)

8.5. Lamp Replacement

Due to the circuit complexity, alignment procedures, and test equipment required
- **The read lamp should only be replaced by X-Rite or an authorized X-Rite Service Center.**

The lamp is monitored for intensity and failure warnings will be displayed if a problem occurs.

The lamp should last approximately one million measurements and is covered by a one year limited warranty. Refer to the Limited Warranty statement on page iii.

A1 Specifications

Measuring Functions:	Absolute	Difference	Indices:
CIE XYZ		$\Delta(XYZ)$	
X% Y% Z%		$\Delta(X\% Y\% Z\%)$	
CIE Yxy		$\Delta(Yxy)$	
CIE LAB		$\Delta(L^*a^*b^*)$	ΔE^*_{ab}
Hunter LAB		$\Delta(Lab)$	ΔE
CIE LUV		$\Delta(L^*u^*v^*)$	ΔE^*_{uv}
CIE LCH		$\Delta(L^*C^*H^*)$	$\Delta E^*(ab, CMC, \text{ or } uv \text{ space})$
			Whiteness per ASTM E313
			Whiteness & Tint per CIE
			Yellowness per ASTM E313
			Yellowness per ASTM D1925
Display:	2 row by 16 character Supertwist dot matrix LCD		
Measuring Geometry:	0°/45°, fiber optic pickup, multi-sensor array		
Measuring Area:	8.0mm & 4.0mm (20mm optional)		
Light Source:	Gas filled tungsten lamp, approx. 2856°K (corrected for D65 illuminant)		
Illuminant Types:	C, D ₆₅ , D ₅₀ , A, F2 (cool white fluorescent), F7 (broad-band white fluorescent), F11 (TL84), & F12 (Ultralume 3000)		
Standard Observers:	2° & 10°		
Measurement Range:	0 to 200% reflectance		
Spectral Range:	400nm - 700nm		
Spectral Interval:	20nm (15nm bandwidth)		
Resolution:	.01%		
Inter-Instrument Agreement:	948:	0.40 ΔE^*_{ab} average (Based on average of 12 BCRA tiles)	
	968:	0.20 ΔE^*_{ab} average (Based on average of 12 BCRA tiles)	
Short Term Repeatability:	948:	0.10 max ΔE^*_{ab} on a white ceramic (20 measurements)	
	968:	0.05 max ΔE^*_{ab} on a white ceramic (20 measurements)	
Warm Up Time:	None		
Measurements Per Charge:	Approx. 1000 typical		
Measuring Time:	Approx. 2 seconds		
Data Interface:	Patented Bidirectional RS-232, 300 to 9600 baud (user selectable), bipolar output		
Power Supply:	Six rechargeable AA NiCad batteries 7.2v total rated @ 600mAh (included)		
Charge Time:	Approx. 14 hours		
AC Adaptor Requirements:	948/968	90 - 130VAC, 50 - 60Hz, 18W Max.	
	948X/968X	180 - 260VAC, 50 - 60Hz, 20W Max.	
		12VDC @ 700ma: Positive Tip	
Operating Temp. Range:	50° - 104°F (10° - 40°C)		

Specifications . . . continued

Storage Temp. Range:	-4° - 122°F (-20° - 50°C)
Weight:	2.3 lbs. (1050 grams)
Dimensions:	3 3/16" H x 3" W x 7 3/4" L (81mm H x 76mm W x 197mm L)
Accessories Provided:	Calibration Standard Operation Manual Reference Guide AC Adaptor Carrying Case

X-Rite standards are traceable to the National Institute of Standards and Technology.

This product covered by U.S. Patent 4,591,978 and other patents pending.
Specifications and design subject to change without notice.

A2 **Optional Accessories**

	<u>Part Number</u>
• QA-Master® (Quality Assurance software program)	1255-00
• ColorStart® (948 Quality Control software program)	1220-00
• SpectroStart® (968 Quality Control software program)	1250-00
• 4/8mm Aperture Kit	968-100-08
• 20mm Aperture Kit	968-100-20
• 8mm Aperture Attachment (UV excluding)	968-61-08E
• 948/968 Mounting Fixture	968-80
• Security Cable	418-75
• Portable Thermal Printer (115VAC)	418-113
• Portable Thermal Printer (230VAC)	418X-113
• Interconnect cable for Macintosh computers with 8 pin mini-DIN connector	418-79
• Modular Interconnect Cable (requires adaptor below)	SE108-69
• DB25P DCE (Null Modem) Interface Adaptor	418-70
• DB25S DCE (Null Modem) Interface Adaptor	418-71
• DB25P DTE (Normal) Interface Adaptor	418-80
• DB25S DTE (Normal) Interface Adaptor	418-81
• DB9P Interface Adaptor	418-90
• DB9S Interface Adaptor	418-91
• 4mm Target Window	968-121-04
• 8mm Target Window	968-121-08
• 20mm Target Window	968-121-20

A3 **Factory Presets**

Shown below are the factory presets for the Averaging, Operation, I/O, and Format parameters.

AVERAGING PARAMETERS

Average - 01
Sub Average - 1

OPERATION PARAMETERS

Tone - SOFT
XYZ - ON
Yxy - ON
L*a*b* - ON (CIE)
L*u*v* - ON
L*C*h° - ON (ab space)
Whiteness - ON
Yellowness - ON
Auto Reference - ON

RS232 I/O PARAMETERS

RCI - ON
BAUD RATE - 1200
CR/LF - Carriage Return With Line Feed
HANDSHAKE - OFF

FORMAT PARAMETERS

Printout - AUTO
Comp/Print/Spectral - COMPUTER
All Print - OFF
Print Header - OFF
Print Reference - OFF
Decimal Point - ON

The unit is shipped from the factory with function "L*a*b*" and illuminant/observer "C²." If the memory is reset, the function, illum/obs, and all parameters will return to the settings described above.

A4 Spectrophotometer Stand

X-Rite has an optional mounting fixture available (P/N 968-80). The fixture can hold items that are a maximum of four inches wide, or two inches to the center of the object.

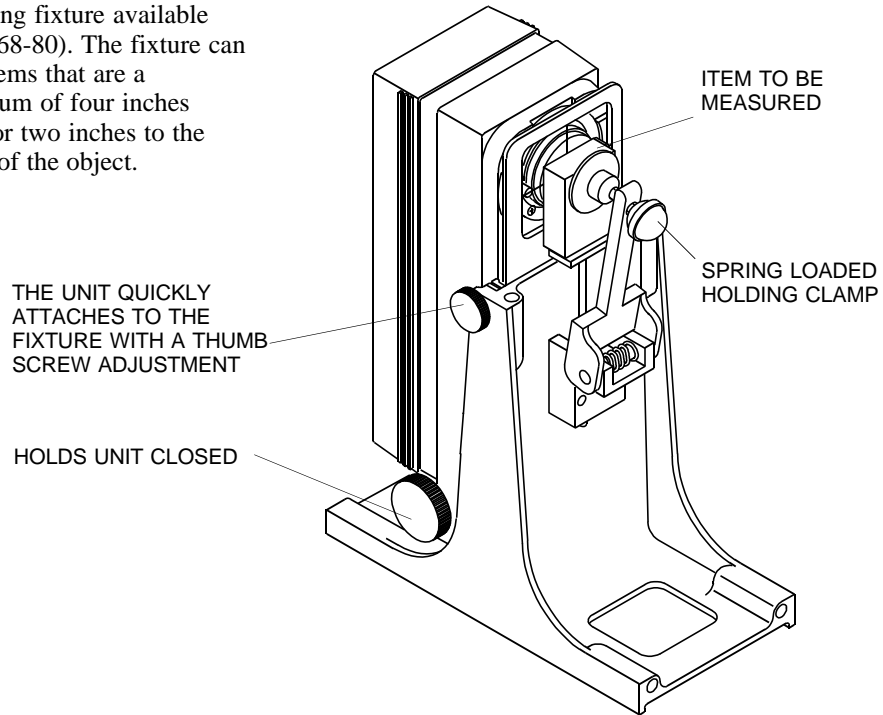

The color check procedure will help you track instrument color performance to assure measurement accuracy. Initially, the three patches on the standard should be measured once a day for a period of 10 days to determine the reference values. Thereafter, a periodic check (once a week depending on usage) is all that is required.

Located on the back of the reference standard envelope is a color check label. The reference data should be recorded there for quick reference.

Reference Data Procedure

To obtain reference values:

- 1) Clean instrument optics and reference standard if necessary.
- 2) Calibrate instrument according to procedure in operation manual.
Note: The reference standard is dramatically affected by smudge marks and dust; and must be kept clean.
- 3) Select L*a*b* absolute function and desired illuminant/observer.
Note: The selected illum/obs must be the same whenever the color check is performed.
- 4) Measure the White (1), Blue (2), and Brown (3) patches on the reference standard.

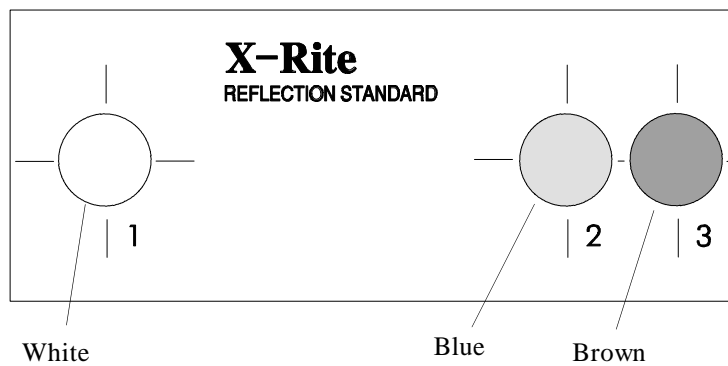

- 5) Record the L*a*b* values for each color on a piece of paper.
- 6) Repeat steps 1-5 for 10 days.



Color Check . . . continued

- 7) After 10 days average the white, blue, and brown values and enter data in the designated place on the color check label.
- 8) Enter date, illuminant, observer, aperture size, temperature, instrument model, and serial number on color check label.
Note: Temperature of the reference standard should be maintained ($\pm 2^{\circ}\text{C}$) throughout color check sequence.

Periodic Color Check Procedure

- 1) Copy reference data located on the color check label to the shaded areas on the color check record located on the next page.
- 2) Perform steps 1-4 in reference data procedure.
- 3) Record the measured white, blue, and brown values and date on the color check record on the next page.
Note: You may want to make several copies of the color check record before entering any data. This will allow you to have additional pages available when they are needed.
- 4) Compare measured values to the reference values.
 - If values are off, clean optics and reference standard and remeasure.
 - Consistent L^* , a^* , or b^* differences exceeding .30 (or obvious trends away from the reference data) may require the unit to be serviced. Contact X-Rite or authorized service center if this is the case.
 - Always verify color performance with the same aperture size, illum/obs, and temperature.



X-Rite, Incorporated—World Headquarters

3100 44th Street, S.W. • Grandville, Michigan 49418 • U.S.A
www.x-rite.com • (616) 534-7663
Toll-Free U.S. Numbers
Tel: 1-888-826-3042 • Fax: 1-888-826-3043
Toll-Free International Numbers
Tel: 1-888-826-3039 • Fax: 1-888-826-3041

X-Rite GmbH

Stollwerkstraße 32 • 51149 Köln • Germany
Tel: (49) 2203-91450 • Fax: (49) 2203-914519

X-Rite GmbH

Sochorova 705 • CZ-682 • 11 Vyskov • Czech Republic
Tel: (42) 0507-328197 • Fax: (42) 0507-328138

X-Rite Asia Pacific Ltd.

Room 808-10 • Kornhill Metro Tower • 1 Kornhill Road
Hong Kong • Tel: (852) 2-568-6283 • Fax: (852) 2-885-8610

X-Rite Ltd.

The Acumen Centre • First Avenue
Poynton, Cheshire • England
Tel: 9-011-44-0-1625-871100 • Fax: 9-011-44-0-1625-871444

X-Rite Méditerranée

Parc du moulin de Massy • 35, rue du Saule Trapu • 91300 Massy • France
Tel: 33-1-69.53.66.20 • FAX 33-1-69.53.00.52

X-Rite Asia Pacific Limited—Japan Office

1-7-11-506 Higashi-Gotanda, Shinagawa-ku, Tokyo 141 Japan
Tel: 03-5447-1607 • Fax: 03-5447-1608