



VeriColor® Spectro Environmental Enclosure

Ensure the accuracy of instrument readings and reduce maintenance costs in harsh environments with this easy-to-use enclosed system that permits operations in severe temperatures and prevents contaminants from affecting the cleanliness or performance of the instrument lens.

VeriColor Spectro Environmental Enclosure Advantages

- **Withstands Harsh Temperatures.** Allows instrument to operate at temperatures up to 75°C (167°F)
- **Reduces Maintenance Time and Expense.** Integral positive forced air system keeps dust, moisture, solvents, and other particulates from contaminating instrument lens
- **Reliable.** Includes oil/water separator to insure clean, dry air through the enclosure
- **Flexible.** Permits environmental controls based on degree of contaminant threat
- **Maintain Measurement Integrity.** Two-inch measurement distance to sample
- **Rugged.** Made of sturdy rolled steel and powder coated for years of service

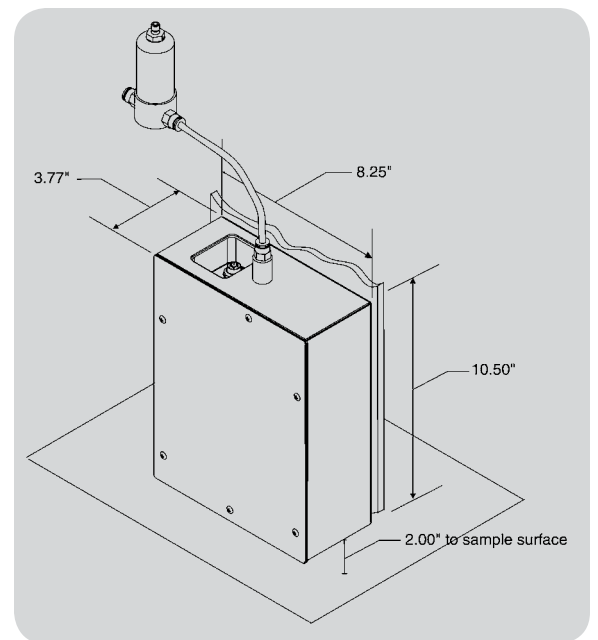

Recommendations for Use

1. Where the enclosure is being used only for added resistance to contamination of the lens and not to extend the thermal range of operation, an airflow rate may be used anywhere across the broad range of 1 to 8 CFM as needed by that particular application to prevent contamination.
2. When the enclosure is being used to enable operation in extended thermal environments, use a mounting method that avoids releasing excessive conducted or radiated heat into the enclosure.
 - A continuous air flow of 3 CFM with an inlet temperature of 30° C (86° F) or less will allow operation of the VS410 to be extended up to a free air temp surrounding the enclosure of 70° C (158° F).
 - If the airflow is maintained at 4 CFM the enclosures environment may be extended to 75° C (167° F).
3. Airflow should be maintained any time a potential optical contaminant is present or the ambient temperature to which the unit would be exposed is in excess of 50° C (122° F). Airflow shall be cool (less than 30° C (86° F), clean, and free from condensation of water or liquids.

Included:

- Enclosure
- 10' (3.08 m) air line
- Oil/water separator
- Mounting Hardware
- Mounting Instructions

* Individual components not sold separately

X-Rite: Your source for accurate color. On time. Every time.

X-Rite is a world leader in providing global color control solutions for manufacturing and quality management requirements.

We lead the industry in offering service options to ensure uninterrupted performance of all X-Rite products. Training and educational resources are available globally and online for both new and experienced users to optimize their color measurement capabilities.

Visit xrite.com for more information about X-Rite products. X-Rite customers worldwide may also call the Applications Support team at CASupport@xrite.com or Customer Service at 800-248-9748.

X-RITE WORLD HEADQUARTERS

Grand Rapids, Michigan USA • (800) 248-9748 • +1 616 803 2100
© 2007, X-Rite, Incorporated. All rights reserved.